

LAYHER ALLROUND SCAFFOLDING® CATALOGUE 2021/2022



Edition 04.2021
Ref. No. 8116.258

Quality management
certified according
to DIN EN ISO 9001



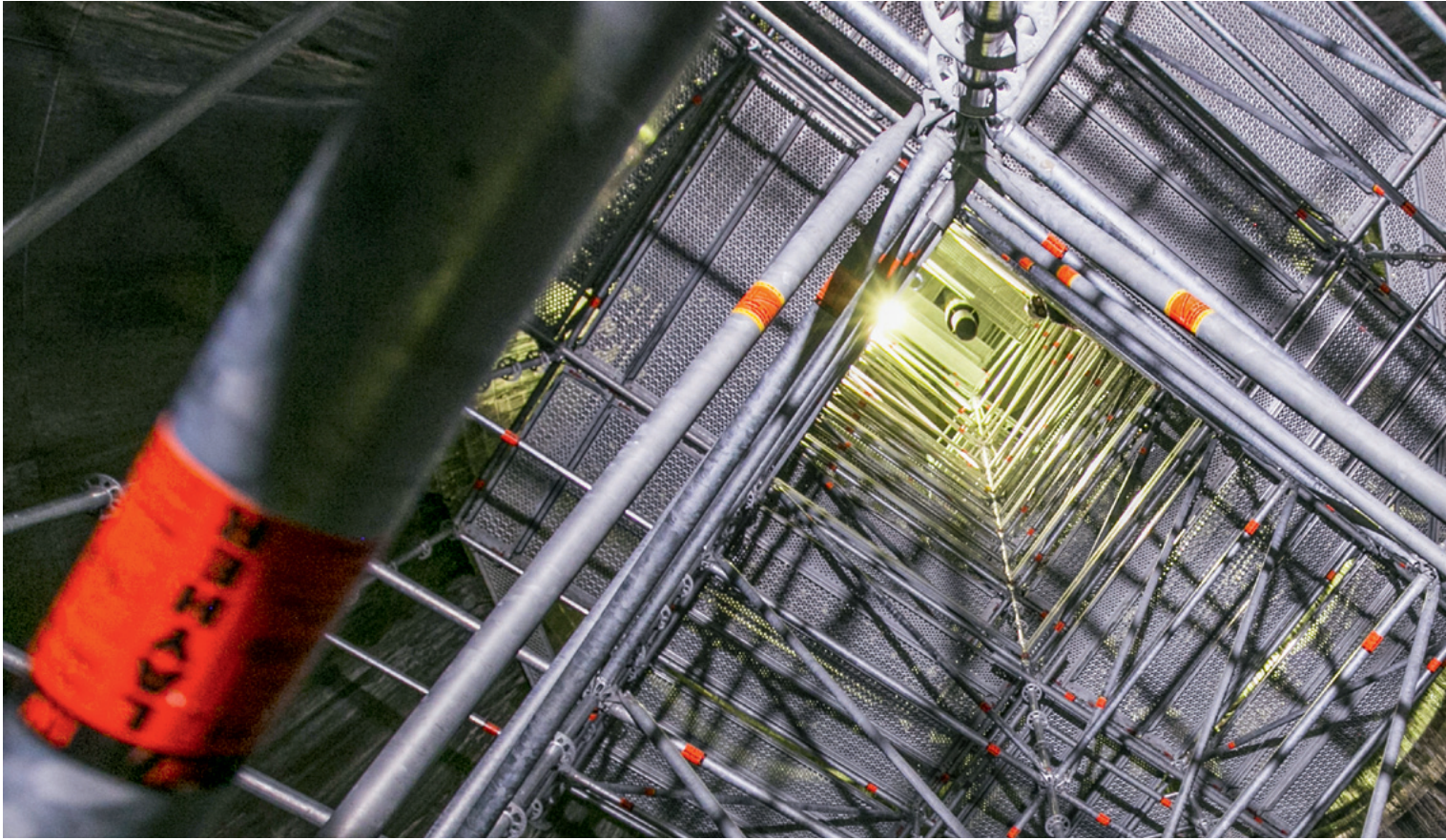

COMPANY FROM PAGE 4



Quality "Made by Layher"	4
More Speed	5
More Safety	5
More Proximity	5
More Simplicity	5
More Future	5

SCAFFOLDING PLANNING FROM PAGE 8



Software for scaffolding construction	8
---------------------------------------	---

BASIC COMPONENTS FROM PAGE 10



Scaffolding base plates	10
Vertical support elements	12
Allround guardrail system	14
Horizontal support elements, Side protection	16
Diagonal bracing	20
Scaffolding decks, U-suspension	22
Scaffolding decks, O-suspension	26
Steel planks, gap decks	28
Toe boards	30
Couplers, Spare Parts, accessories, anchoring	32



MIXED REALITY



In this catalogue, you can find images highlighted with the symbol for mixed reality.

By using the Layher App, you bring these scaffolding structures to life. Learn more and download the app: **app-en.layher.com**

EXTENSION COMPONENTS FROM PAGE 34



Brackets	34
Pedestrian protection	36
Stairway ascents, outside accesses	38
FW System	48
Bridging system	50
FlexBeam	52
Allround Wall Bracket	54
STAR frame	56
Shoring, construction stairtowers	58
Flat roof side protection	64
Advance guardrail system	64
Mobile scaffolds, pallets, tools	66

PRODUCT-PORTFOLIO



The Layher product range – all catalogues at a glance	
SpeedyScaf	Ref. No. 8102.262
Allround Scaffolding	Ref. No. 8116.258
System-free Accessories	Ref. No. 8103.260
Protective Systems	Ref. No. 8121.260
Event Systems	Ref. No. 8111.233
Access Technology	Ref. No. 8118.233

NOTICE

Subject to technical modification. Component weights are subject to fluctuations due to tolerances and may therefore diverge from what is specified.

Steel components are hot-dip galvanized according to EN ISO 1461 and DAST guideline 022. Connection parts or other small pieces can be galvanized according to EN ISO 4042.

Our deliveries shall be made exclusively in accordance with our at the conclusion of contract valid General Terms of Sale. These include the following provisions: The place of performance is Gueglingen-Eibensbach. Title to the delivered goods shall be retained until full payment has been made. The fully GTC you can find here: **gtc.layher.com**

Please request the specific instructions for assembly and use when ordering. Protected by copyright. Not to be reproduced, either in whole or in part. Misprints and errors excepted.

QUALITY MADE BY LAYHER



Headquarters in Eibensbach



Plant 2 in Gueglingen

QUALITY MADE IN GERMANY.

Quality made by Layher comes from Gueglingen-Eibensbach. Our company has set down deep local roots since it was established. Right up until today, development, production and management, sales and export department are all in one place, where the conditions are best for achieving quality made by Layher: in Gueglingen-Eibensbach. The two locations together cover a surface area of 318,000 m². This includes more than 148,000 m² of covered production and storage areas.

MORE POSSIBILITIES. THE SCAFFOLDING SYSTEM.

This brand promise made by Layher is the expression of a brand philosophy that we've been living by for over 75 years. More speed, more safety, more proximity, more simplicity and more future: values with which we strengthen our customers' competitiveness in the long term. With our innovative systems and solutions, we're working all the time on making scaffolding construction even simpler, even more economical and, above all, even safer.

SUSTAINABILITY AT LAYHER.

We've long been acting with a clear focus, with a view to both economic and ecological sustainability in all our process steps. Social responsibility towards employees, clients and society as a whole are at the very centre of this. We're a dependable employer, active in protecting our resources. The sparing use of work materials as a feature of our sustainable approach is fundamental to how we see ourselves: we already take care to ensure sustainable building methods when planning a new production facility, for example by greening the roofs or using photovoltaic systems. We also value locations that are close by, avoiding unnecessary CO₂ emissions due to long traffic routes. The topic of sustainability is firmly embedded in Layher's organisational structure thanks to its energy management team. Their work has paid off in particular in the form of DIN EN ISO 50001 certification.



Discover the world of Layher in its company film at:
yt-image-en.layher.com





MORE SPEED

High level of material availability, effective delivery service and quick assembly and dismantling of the scaffolding systems thanks to 100% fitting accuracy.



MORE SAFETY

Outstanding quality and precision coupled with a long service life – confirmed internationally through independent certifications, inspections and approvals. Continuity and long-term partnership.

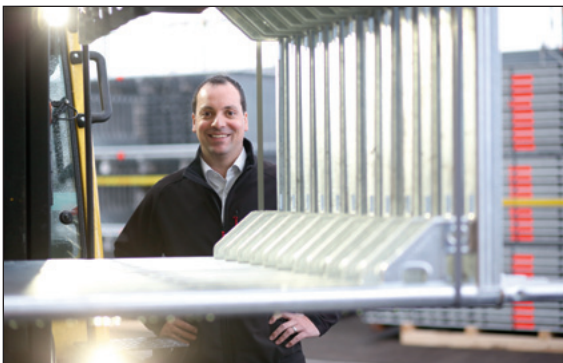

MORE PROXIMITY

Comprehensive personal consultation and close-knit delivery network. Global presence through our own subsidiaries. Family-owned company that works closely with its customers.



MORE SIMPLICITY

Economical scaffolding systems that have been proven in practice, available with an extensive product range. Cross-system combinations for versatile use. Rapid decision making thanks to efficient structures and processes.



MORE FUTURE

Thanks to permanent product innovations and the improvement of existing parts. By opening up new areas of business. With an integrated system to ensure high profitability and retention of investment value. Through an extensive range of training opportunities and seminars to ensure that customers are always right up-to-date with the latest technical and commercial developments.

Layher Lightweight: Through the use of high-tensile steel, a new production process, and an improved design, we have succeeded in minimising the weight of the core components of our systems – while maintaining or raising load-bearing capacity.





THE VERSATILE SOLUTION: LAYHER ALLROUND SCAFFOLDING®

The proven combination of positive and non-positive connections in rapid bolt-free system technology with AutoLock function permits connections that are automatically right-angled, obtuse-angled and acute-angled as required, with built-in safety at the same time. Layher Allround Scaffolding has become a synonym in the marketplace for modular scaffolding.

This original system has been continually improved since it was launched in 1974, and offers an impressive variety of uses: at every construction site, in industry, chemical plants, power stations, shipyards and for events. As scaffolding for working, protection, facades or for support, as internal or birdcage scaffolding, or as rolling towers.

Even with very difficult layouts and architecture styles and with heightened safety requirements, Allround Scaffolding is always the faster, safer and more economical solution.

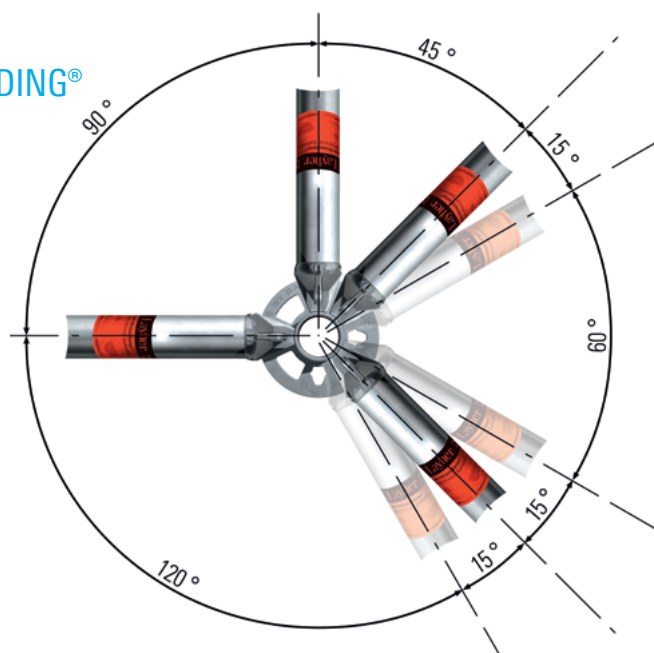

THE BENEFITS FOR YOU

- ▶ Higher fitting performance and higher and more shipping space thanks to special high-tensile steel and constructive improvement, reducing weight of components and raising load-bearing capacity.
- ▶ No time-consuming fitting of spigots and double storage, thanks to a single standard with integrated spigot for supported and suspended scaffolding.
- ▶ The integrated scaffolding system for easy and complicated applications is fully combinable with all former generations. Maximum investment protection thanks to long durability, purchase availability for decades and continuous enhancements.
- ▶ Improved working safety and time saving on assembly thanks to the AutoLock function.
- ▶ Improved working thanks to the lower weight in the system and more headroom by approx. 10 cm.

As work scaffolding and safety scaffolding at the facade, as birdcage, trestle and suspended scaffolding, or as a rolling tower – the right scaffolding at all times and for every job and requirement. For very difficult ground plans and anchoring conditions, for very irregular structures, and for jobs with increased safety requirements.

General building authority approval: The various scaffolding systems of Layher Allround Scaffolding are approved with various general building authority approvals: Z-8.22-64 Layher Allround Steel, Z-8.22-64.1 Layher Alu-Allround, Z-8.22-939 Layher Allround LW, Z-8.22-949 Layher Allround LWv and Z-8.1-919 Layher Allround STAR 0.73 m wide and Z-8.1-969 Layher Allround STAR 1.09 m wide. Each of these general building authority approvals has its own approval object. The scaffolding components for use in each of the scaffolding systems are derived from the respective general building authority approval.

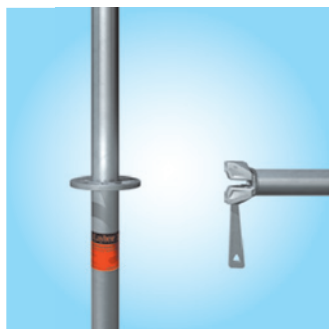

It's this easy: Turning the ledger and slightly tilting it before assembly activates the AutoLock function.



As the wedge head is pushed over the rosette, the wedge drops automatically into the recess and is **immediately secured against any possibility of shifting or dropping out.**

This means: safe 1-man assembly, whatever the height.



The flat rosette without recesses or bulges prevents it getting clogged with the dirt, whatever the type, that makes assembly difficult.



A hammer blow on the wedge transforms the positive connection into a superbly strong non-positive one. (Use 500 g metal hammer until the blow bounces off).

THE INTEGRATED SCAFFOLDING SYSTEM: APPLICATION-ORIENTED ACCESSORIES

Protective Roofs

Layher weather protection roofs can be used in a number of variants depending on their span, the snow load or the wind load. That saves you real money when planning temporary weather protection roofs. For easy use on the site, clearly set-out material and loading capacity tables for snow and wind loads are available for you. Protective roofs are not a one-off solution for Layher, but a standard product – this ensures readiness for immediate delivery.



Protect System

With its Protect System, Layher offers an enclosure system that fits in with Allround Scaffolding and SpeedyScaf. It is used for example for pedestrian protection in combination with the Allround bridging system and also for environmental protection and noise reduction. Highly economical to use thanks to quick and easy assembly in a simple and logical assembly sequence, and the frequent use of a few system components. The Layher Protect System is not a one-off solution for Layher, but a standard product – this ensures readiness for immediate delivery.



ANTI-THEFT PROTECTION AND ADVERTISING IN ONE

Layher Individual

Xtra-N-decks, Robust decks, Stalu decks, steel decks can be stamped individually. Wooden toe boards can be printed according to your preferences.



More interesting expansion parts, you can find in the brochure Expansion Parts in Industrial Scaffolding Construction.

Layher LayPLAN

Time and material are crucial factors in scaffolding construction. To make the most efficient use of both, the Layher range includes the practical LayPLAN scaffolding planning software.

With the several software packages LayPLAN CLASSIC and LayPLAN CAD, it is possible to plan scaffolding structures from simple, small facade scaffolding up to complex industrial scaffolding or protective roofs and grandstands.

LayPLAN CLASSIC

With the LayPLAN CLASSIC modules for Allround Scaffolding and SpeedyScaf, individualised scaffolding solutions can be configured quickly and easily: whether they're for circular or facade scaffolding made from SpeedyScaf, for birdcage scaffolding and free-standing towers made from Allround Scaffolding, or for structures with temporary roofs. Once the dimensions and the required assembly variant have been entered, LayPLAN CLASSIC delivers within seconds a scaffolding proposal, including anchoring, bracing and side protection. During the design phase, the overall length, standing heights and areas are continuously calculated and displayed to reflect the current plan. A materials list can also be created at the click of a button and then printed out, together with an assembly sketch for the area to be enclosed in scaffolding plus the total weight. This also helps with the logistics – the required material is guaranteed to be there where it's needed. Scaffolding erectors benefit from more certainty when planning the commercial and technical details, from optimised use of stocks, and from full cost transparency at every stage of the project.

After finalisation of the scaffolding proposal, the LayPLAN Material Manager provides you with complete lists of required parts to ensure you always have precisely the material you need at the site.

LayPLAN CAD

For more complex structures, LayPLAN CAD is available. This is a plug-in for Autodesk AutoCAD. It enables 3-dimensional planning of scaffolding structures of all types.

Thanks to integration into the LayPLAN system, the basic planning can be handled in automated form using the proven LayPLAN CLASSIC. Project data can be quickly recorded using input masks, ensuring a time saving for every order. The data are then simply exported into the AutoCAD program, which offers further possibilities for detailed 3D planning. A visual collision check is possible with the aid of volume rendering. Using a convenient search function with preview image, scaffolding planners will find not only an extensive library of individual Layher parts, but also assemblies already prefabricated for even faster design work. The detailed drawings can then be printed out. A transfer to visualisation or animation software is also possible without any problem. This allows projects not only to be planned economically and also adapted precisely to actual requirements, but also to be presented professionally to customers.

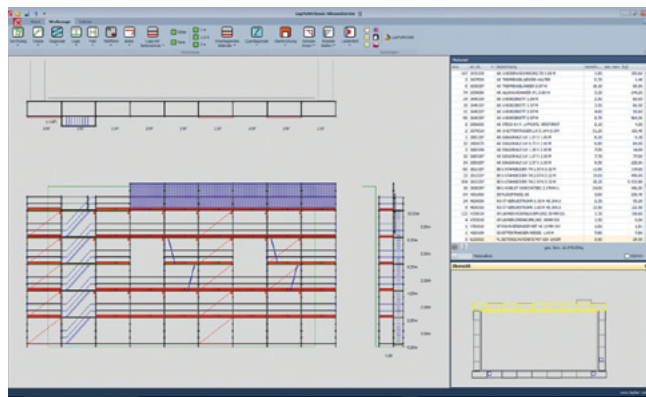

Allround Facade Scaffolding

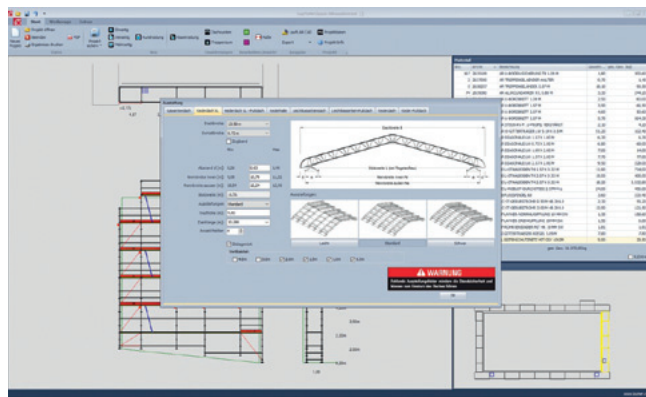

Weather protection roof on Allround support Scaffolding

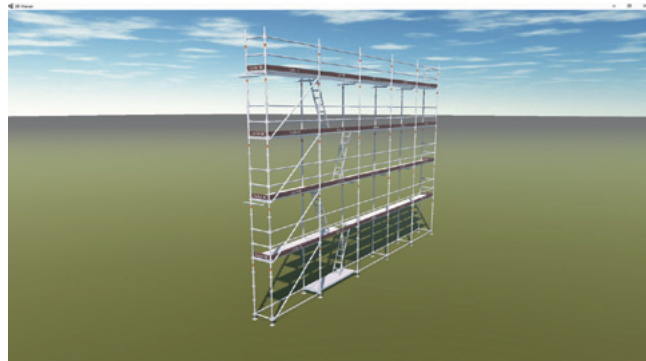

LayPLAN CLASSIC 3D-Viewer

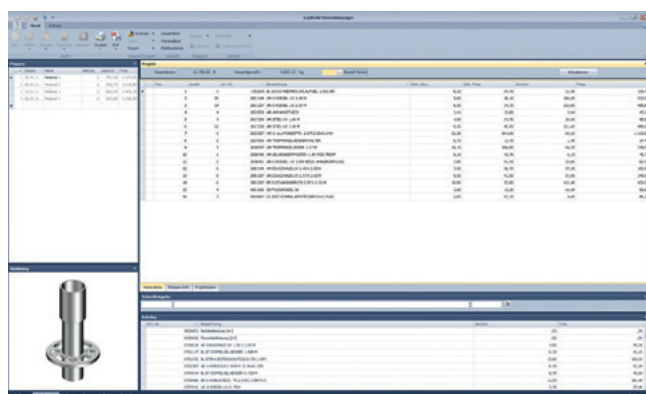

Component images LayPLAN Material Manager
Part of LayPLAN CLASSIC and LayPLAN CAD

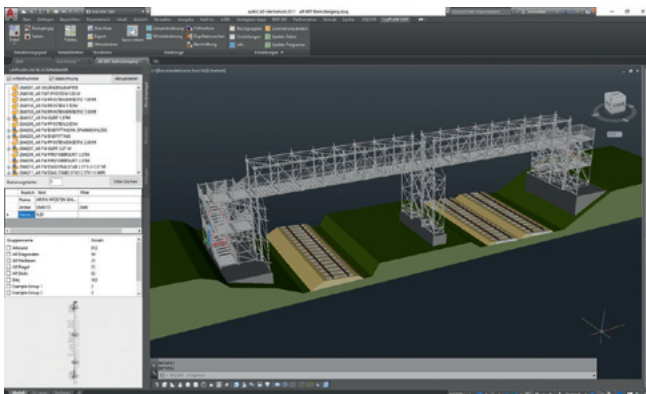

Planning of individualised scaffolding structures in LayPLAN CAD

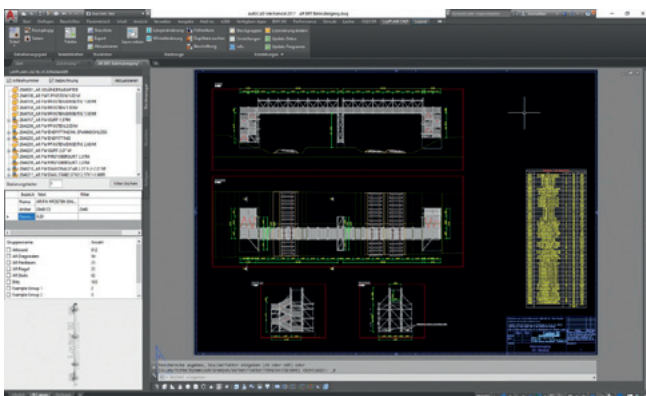

Creation of planning documents with integral material lists in LayPLAN CAD

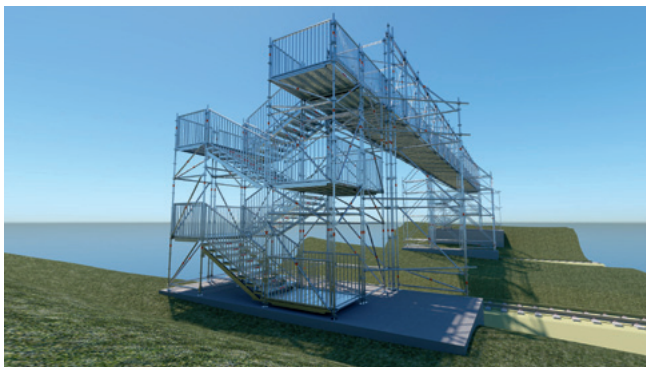

Use of 3D models in 3D viewers or 3D PDF or for visualisation

Layher LayPLAN to RSTAB

For structural strength verification of scaffolding structures, frame analysis programs are generally used. Using the LayPLAN TO RSTAB module, all modelling-relevant information about an Allround Scaffolding structure is imported three-dimensionally into the RSTAB frame analysis program from Dlubal. Automated transmission of the information means that re-entering the model data is not needed. This means that the user will benefit from an enormous time saving as well as avoid a possible source of errors during modelling.

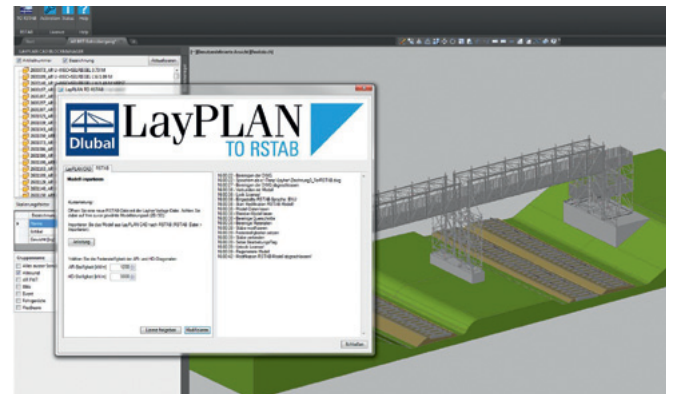

Transmission of model data with the aid of LayPLAN TO RSTAB

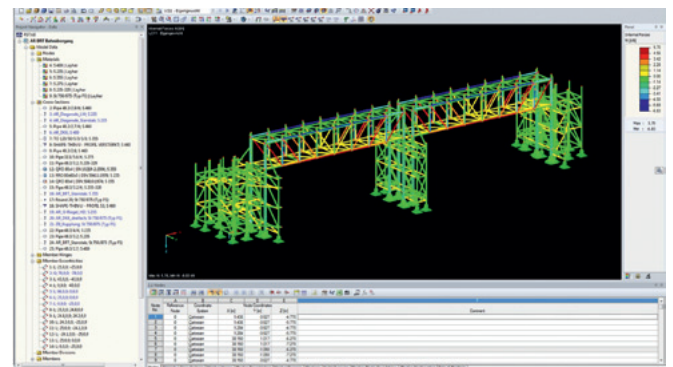

Structural strength computations based on definition of nodal supports and loads

How can I acquire LayPLAN?

Registration and all the ordering processes can be conveniently accessed at the Layher website: <http://software.layher.com>

A contact form gives you the data to access our software portal, where you can download a 30-day test version and also find the order form for the full version.

Pos.	Description	Ref. No.	
1	LayPLAN CLASSIC scaffolding configurator for SpeedyScaf, Allround Scaffolding, weather protection roofs and rolling towers	6345.102	
2	LayPLAN CAD plug-in for AutoCAD, for designing complex scaffolding in 3D and for developing scaffolding proposals from LayPLAN CLASSIC	6345.103	
3	LayPLAN TO RSTAB	6345.104	

WS = wrench size PU = packaging unit = available ex works = delivery time on request = only available in this packaging unit = the approval process is not yet completed

IND = Layher Individual possible – see page 7

Scaffolding base plates

For load transmission and ground adaption, choose between different height-adjustable **base plates 2–5** with sturdy and self-cleaning round threads, with colour and notch markings to provide protection against overwinding. Make sure that there are sufficient load-distributing surfaces. For all inclined erection surfaces, e.g. in combustion chambers or ship hulls, **swivelling base plates 60, reinforced 4** are used.

The round threads of all Layher scaffolding spindles have an outside diameter of 38 mm and a pitch of 8.1 mm. The wing external dimension of the spindle nut is 205 mm. The dimensions of the foot plate are 150 x 150 mm.

Load capabilities of spindle cross-section as per DIN EN 12811-1

Spindle type	N_{Rd} [kN]	M_{Rd} [kNm]	V_{Rd} [kN]
normal	97.7	83.0	36.0
reinforced	119.9	94.5	44.1
solid	288.0	157.0	106.0

The **head jack 7/8** and **10/11** accommodates wood sections or steel beams and serves to adjust height and introduce loads. The solid head jacks and base plates can be recognized by the hexagonal opening provided in them.

The **swivelling top spindle 10** can be used to install supports (e.g. wood sections) with an inclination of up to max. 5% to the horizontal in the longitudinal and transversal directions, thus eliminating the need to level with a wedge. Greater loads can be supported thanks to the articulated mounting of the top plate and the resulting centric introduction of vertical forces into the spindles.

The **cross head jack 45, solid 11** serves to accommodate wood sections, glued binders or steel beams in falsework and supporting scaffolding. It stabilizes the supports against tilting, and it is possible to use one or two formwork supports. Height adjustment is performed using the spindle nut. The cross head jack is suitable for all common formwork supports.

Wedge spindle swivel coupler 12

For connection of a tube dia. 48.3 mm to a scaffolding spindle at any angle.

With the **adjustment plate 13**, rigid base plates can be fully beared on inclined ground. By turning the plate, the inclination can be continuously adjusted up to 16% without reducing the load-bearing capacity.

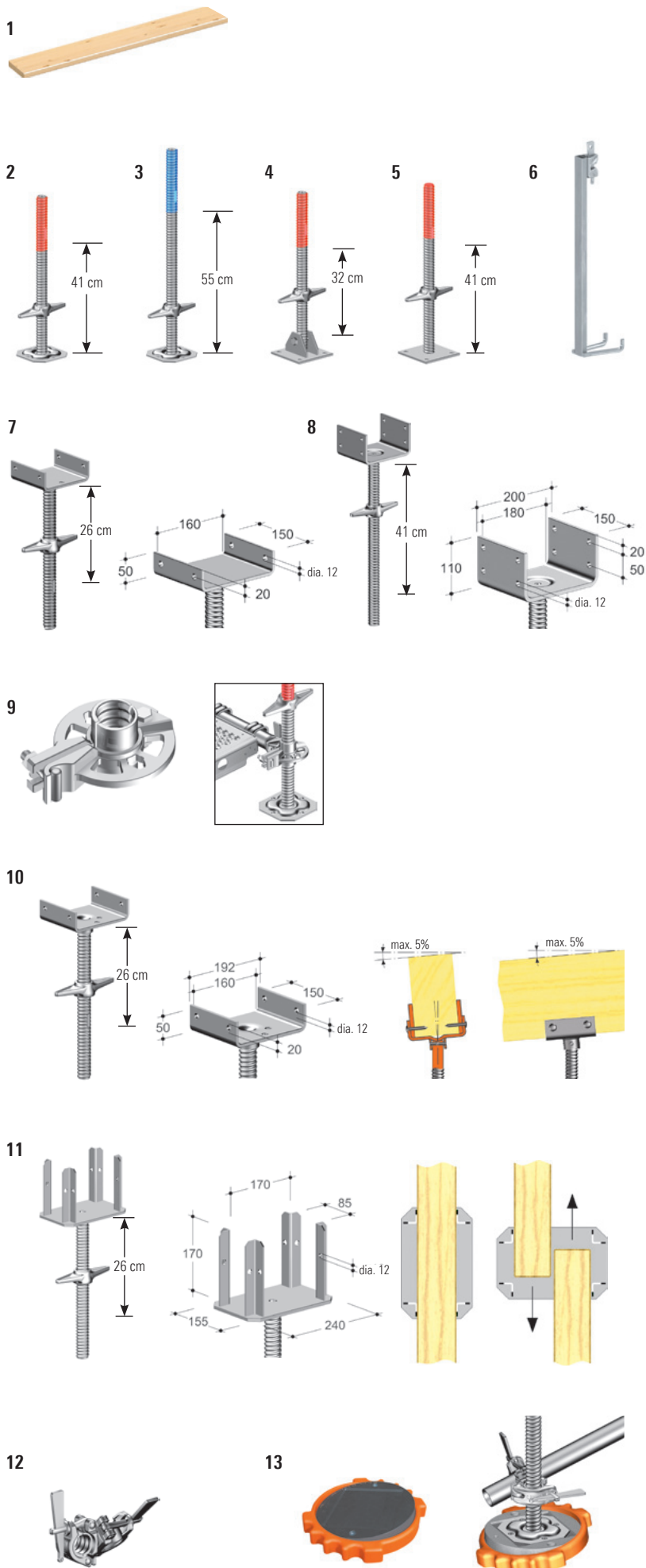

Pos.	Description	Dimensions L/H x W [m]	Weight approx. [kg]	PU [pcs.]	Ref. No.
1	Scaffolding plank for load distribution 45 mm high, freshly sawn, sorting category S 10	1.00 x 0.24	5.2	80	3816.100 ⌚
		1.50 x 0.24	7.8	80	3816.150 ⌚
2	Base plate 60 (max. spindle travel 41 cm)	0.56	3.6	200	4001.060
3	Base plate 80 , reinforced (max. spindle travel 55 cm)	0.73	4.9	200	4002.080
4	Swivelling base plate 60 , reinforced (max. spindle travel 32 cm), ensure sufficient structural strength	0.58	6.1	250	4003.000
5	Base plate 60 , solid, without lock (max. spindle travel 41 cm)	0.58	6.7	200	5602.060 🇩🇪
6	Spindle attachment with wedge head	0.60	2.0	150	2602.100 🇩🇪
7	Head jack 45 , solid, 16 cm (max. spindle travel 26 cm), width of fork 16 cm	0.45	6.6	100	5314.045 🇩🇪
8	Head jack 60 , reinforced, 18 cm (max. spindle travel 41 cm), width of fork 18 cm	0.60	8.0	100	5316.060 🇩🇪
9	Rosette with thread , clampable	WS 19	0.12	25	2602.119 🇩🇪
		WS 22	0.12	25	2602.122 🇩🇪
10	Swivelling head jack 45 , solid (max. spindle travel 26 cm), width of fork 16 cm	0.45	7.3	100	5312.045 🇩🇪
11	Cross head jack 45 , solid (max. spindle travel 26 cm), opening dimensions 8.5/17 cm	0.45	6.9	90	5315.045 🇩🇪
12	Wedge spindle swivel coupler		1.8	25	4735.000 🇩🇪
13	Adjustment plate for base plate of glass-fibre-reinforced polyamide plastic, inclination 0 – 16%	dia. 0.30	1.3	250	4000.400 🇩🇪

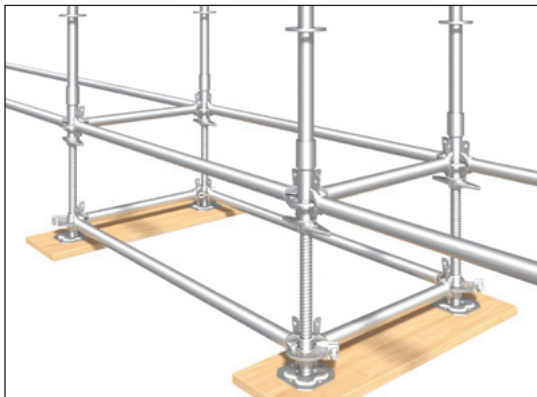

The **rosette with thread, clampable 9** can be attached to the thread of the Layher base plate or head jack. This rosette can be used, when the spindle nut is undone, for bracing in the longitudinal, transverse and diagonal directions. Up to six connections are possible.

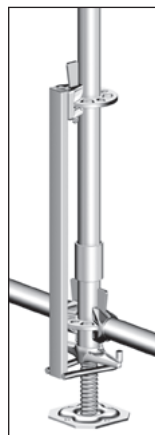

The **spindle fixture with wedge head 6** serves to secure the base plate and the base collar against falling out when moving scaffolding with a crane.



WS = wrench size PU = packaging unit 🇩🇪 = available ex works ⌚ = delivery time on request 🇩🇪 = only available in this packaging unit 🇩🇪 = the approval process is not yet completed

IND = Layher Individual possible – see page 7

Vertical support elements of steel and aluminium

Standards are available in hot-dip galvanized steel tubing, dia. 48.3 mm, and aluminium tubing, dia. 48.3 mm, with rosettes at every 50 cm for a maximum of eight connections.

Four small openings in the rosette determine right-angled connections, four larger openings permit connections at any angles.



For use as suspended scaffolding or for moving by crane, only following standards may be used: **standards without spigot 1c+e** together with **spigots 2**, **standards 1i** together with **spigots 2** or **standards LW 1d** with integrated spigot.

For connecting of each standard, you can use **hinged pins 3** or **special bolts M12 x 60 4**. The spigots should always be bolted into the standard with the special bolts.

The standard LW with integrated spigot 1d – only one standard for stand or suspended scaffolding structures. Thanks to the transmission of tension load no different standards are necessary.

The **rosette, clampable 5**, can be connected to any point on the standard – tightening torque 50 Nm – and allows up to six ledgers or diagonal braces to be connected to it. This permits flexible solutions between the rosettes even when connected to SpeedyScaf. Loading table available on request.

The **base collar 7**, with rosette and the height-adjustable base plate form the scaffolding base. The vertical standard is placed into the base collar for further construction.

The **base collar, long 8**, is required with aluminium Allround standards. For Allround rolling towers it facilitates a correct securing of the castors with locks against falling out.

The **standard lock 0.50 m 6** can be used to bridge standard joints, for example when moving scaffolding using a crane or for suspended scaffolding. Permissible load capacity: 18.8 kN.

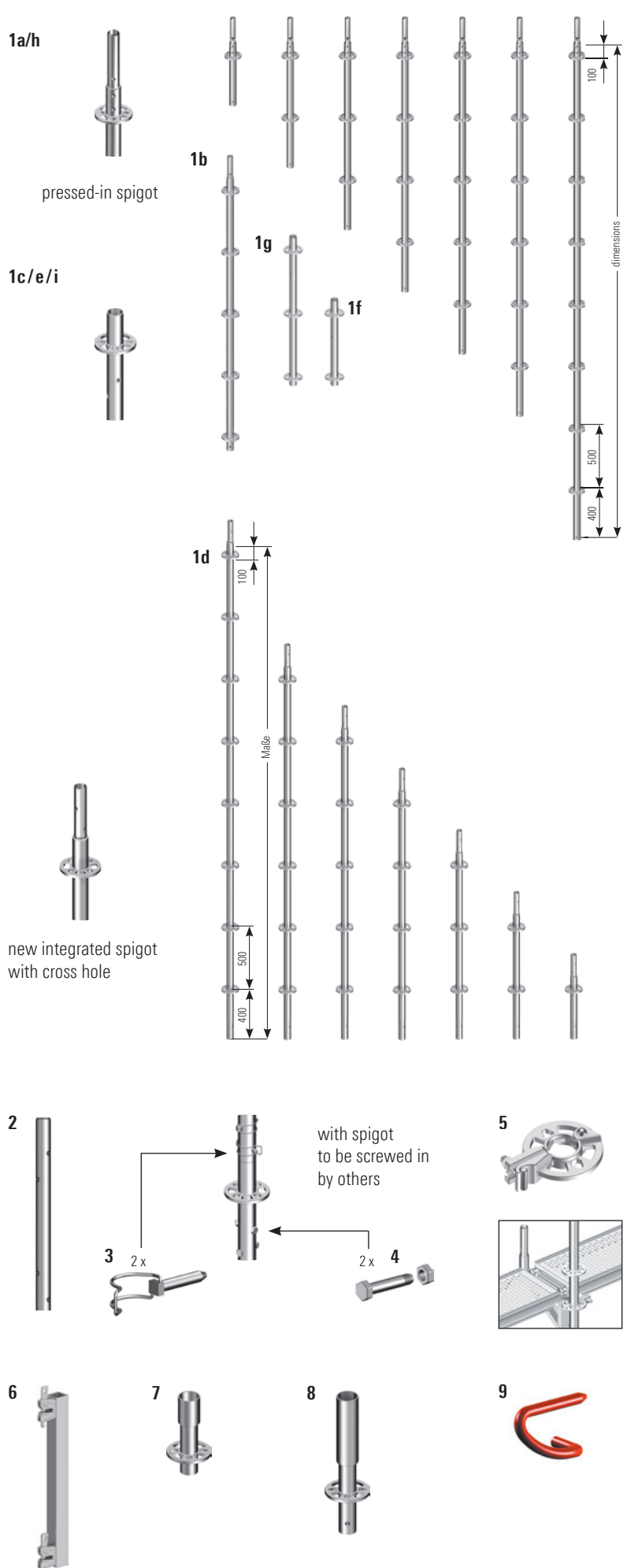

Pos.	Description	Dimensions L/H x W [m]	Weight approx. [kg]	PU [pcs.]	Ref. No.	
1a	Standard, steel, with pressed-in spigot	0.50	3.2	240	5603.050	
		1.00	5.5	28	2603.100	
		1.50	7.8	28	2603.150	
		2.00	10.1	28	2603.200	
		2.50	12.4	28	2603.250	
		3.00	14.6	28	2603.300	
		4.00	19.2	28	2603.400	
1b	Initial standard LW, steel, with pressed-in spigot for use in the lowest scaffolding level without base collar or for assembly of the modular stairtower, with 5 rosettes	2.21	10.0	28	2617.221	
1c	Standard, steel, without spigot e.g. for receiving head jacks, or for suspended scaffolding use the spigot Ref. No. 2605.000	0.50	2.5	300	2604.050	
		1.00	4.6	28	2604.100	
		1.50	6.8	28	2604.150	
		2.00	9.0	28	2604.200	
		2.50	11.7	28	2604.250	
		3.00	13.7	28	2604.300	
1d	Standard LW, steel, with integrated spigot with cross hole for use in stand and suspended scaffolding	0.50	2.7	240	2617.050	
		1.00	4.9	28	2617.100	
		1.50	7.1	28	2617.150	
		2.00	9.3	28	2617.200	
		2.50	11.5	28	2617.250	
		3.00	13.7	28	2617.300	
		4.00	18.1	28	2617.400	
1e	Standard LW, steel without spigot for scaffolding layer	0.50	2.5	300	2619.050	
		1.00	4.6	28	2619.100	
		1.50	6.6	28	2619.150	
		2.00	8.8	28	2619.200	
		2.50	11.7	28	2619.250	
		3.00	13.7	28	2619.300	
1f	Standard LW, 0.67 m, with 2 rosettes, without spigot with integrated base collar	0.67	3.3	200	2619.066	
1g	Standard LW, 1.16 m, with 3 rosettes, without spigot with integrated base collar	1.16	5.5	28	2619.116	
1h	Standard, aluminium, with pressed-in spigot	1.00	2.2	28	3200.100	
		1.50	3.2	28	3200.150	
		2.00	4.1	28	3200.200	
		2.50	5.0	28	3200.250	
		3.00	5.9	28	3200.300	
1i	Standard, aluminium, without spigot for suspended scaffolding	1.00	1.9	28	3209.100	
		1.50	2.8	28	3209.150	
		2.00	3.8	28	3209.200	
		2.50	4.7	28	3209.250	
		3.00	5.6	28	3209.300	
2	Spigot, steel for standards Ref. No. 2619.xxx and 2604.xxx	0.52	1.6	350	2605.000	
	for Ref. No. 3209.xxx, aluminium	0.52	0.8	250	3209.000	
3	Hinged pin, dia. 12 mm with pan-head		2.0	20	4905.668	
4	Special bolt M12 x 60, with nut		4.0	50	4905.062	
5	Rosette, clampable	WS 19	0.12	1.1	25	2602.019
		WS 22	0.12	1.2	25	2602.022
6	Standard lock, 0.50 m	0.58	4.0	100	2603.000	
7	Base collar	0.24	1.4	500	2602.000	
8	Base collar, long	0.43	2.2	400	2660.000	
9	Locking pin, red, dia. 11 mm		0.2	100	4000.001	

WS = wrench size PU = packaging unit = available ex works = delivery time on request = only available in this packaging unit = the approval process is not yet completed

= Layher Individual possible – see page 7

Allround Guardrail System

For **advancing side protection without additional work steps**, Layher has designed the Allround Guardrail System (ARGS). Using the **ARGS Standard 1** and the **ARGS Guardrails 4**, you can create facade scaffolding using Allround Scaffolding with two-part advancing side protection – on both the inside and the outside – without the use of temporary side protection parts.

Thanks to the innovative guardrail suspension, the ARGS Guardrails can be fitted from the secured level underneath, and then swung upwards together with the ARGS Standard.



During assembly or dismantling, **no assembly direction** for the scaffolding bays has to be adhered to. The ARGS Standard has the same load-bearing properties as a normal 2.00 m long Allround Standard LW. Bracing components such as longitudinal ledgers or diagonal braces can be fitted in the familiar way to the Allround rosettes. That keeps you independent and able to deal flexibly with requirements arising at the site.

The assembly principle | Assembly variant 1:

Outside ARGS, Inside Allround Scaffolding

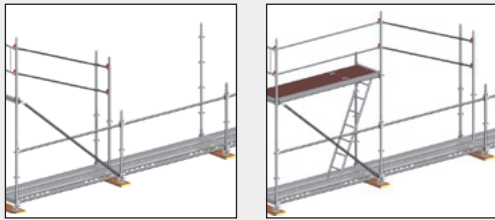

The assembly principle | Assembly variant 2:

Outside and inside ARGS

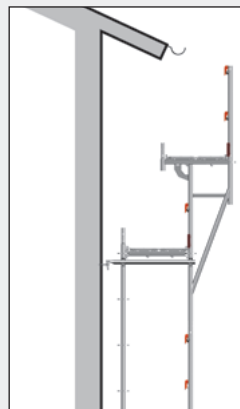
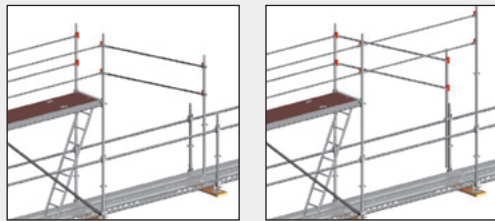

The **ARGS eaves bracket 7** fulfils the work requirements for painters, plasterers and roofers. It replaces material- and time-consuming structures.

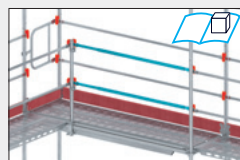



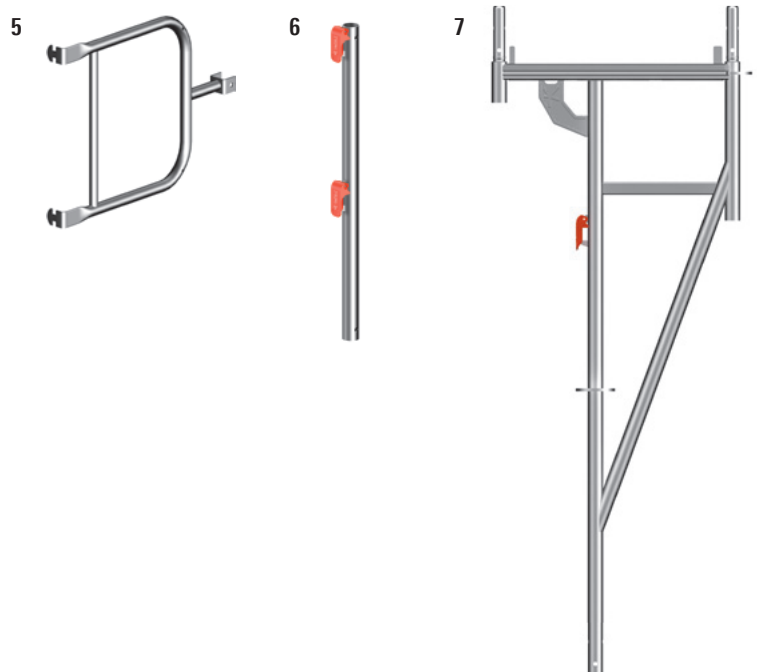
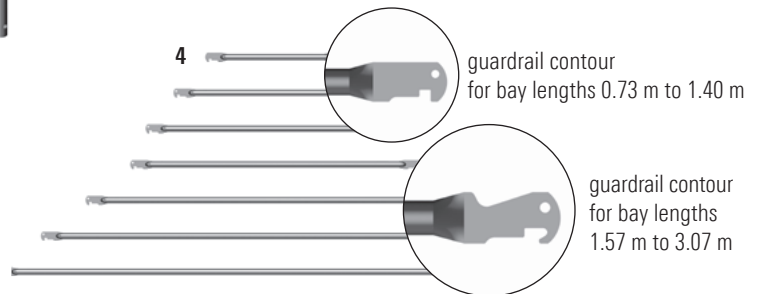
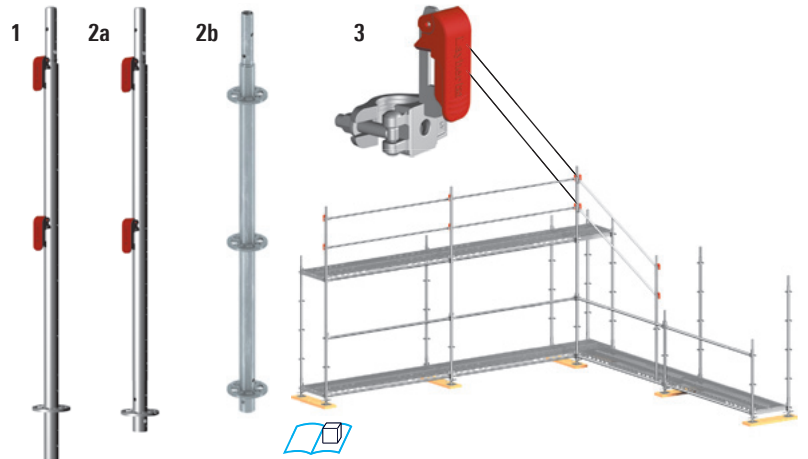











The **telescopic ARGs guardrail 8** allows closing of adjustment bays in inner corners with system guardrails.



More information about the ARGS, you can find in the product film: yt-ags-en.layher.com



Pos.	Description	Dimensions L/H x W [m]	Weight approx. [kg]	PU [pcs.]	Ref. No.	
1	ARGS standard LW	2.00	8.0	28	2602.065 	
2a	ARGS initial standard LW with integrated spigot, with 1 rosette and 2 ARGS guardrail suspensions for quick scaffolding base assembly without base collar – suitable for low scaffolding heights	1.16	5.4	28	2602.116 	
2b	Standard LW with integrated spigot, with 3 rosettes for quick scaffolding base assembly without base collar – allows a full stiffening of the scaffolding base on 1m height with Allround O-ledgers.	1.16	5.7	28	2617.116 	
3	ARGS guardrail adapter , with half-coupler for further construction with guardrails in inner or outer corners		1.0	50	2602.021 	
4	ARGS guardrail lightweight guardrail made of 33.7 mm tube. Assembly without tools ensures rapid installation and removal.	0.73	1.4	140	2602.005 	
		1.09	2.0	140	2602.006 	
		1.40	2.6	140	2602.007 	
		1.57	2.9	140	2602.061 	
		2.07	3.7	140	2602.062 	
		2.57	4.5	140	2602.063 	
		3.07	5.5	140	2602.064 	
5	ARGS double end guardrail closure of the scaffolding at its end. This permits the use of internal guardrails up to the end.	0.73 m	0.73	4.3	60	2602.014 
		1.09 m	1.09	5.6	50	2602.018 
6	ARGS guardrail support , top scaffolding closure	1.00	4.7	50	2602.013 	
7	ARGS eaves bracket	2.00 x 0.73	18.7	50	2602.066 	
8	Telescopic ARGS guardrail lightweight, telescopic guardrail for equalizing bays and inner corners	1.09–1.57	4.4	50	2602.024 	
		1.57–2.57	6.5	50	2602.025 	

WS = wrench size PU = packaging unit  = available ex works  = delivery time on request  = only available in this packaging unit  = the approval process is not yet completed

 = Layher Individual possible – see page 7

Horizontal support elements, side protection

Depending on the scaffolding bay length, deck type and load, **ledgers** made of steel or aluminium are available in cylindrical tube, U-section and reinforcement sections for higher loads. The ledgers are deck beams, bracing elements and guardrails.

The wedge lock connection ensures positive and non-positive connection with central load introduction between standards and ledgers. Safety is already assured in the assembly state because the wedge lock already prevents unintentional disengagement when the wedge is loosely inserted. Longitudinal ledgers can be omitted at deck level if the decks are secured against lifting off by a lift-off preventer.



Slide the wedge head over the rosette.



Insert the wedge into a hole. The component is secure against shifting and falling out.



Hammer down the wedge to provide a non-positive connection. (Use 500 g metal hammer until the blow bounces off.)

Load capacity of O-ledger, steel*							
Ledger length (system dimension) [m]	0.73	1.09	1.40	1.57	2.07	2.57	3.07
Evenly distributed line load q [kN/m]	29.2	14.1	8.8	7.0	4.1	2.7	1.9
Individual load P in centre of bay [kN]	10.1	7.1	5.7	5.1	4.0	3.3	2.7

* Working load

Allround O-ledger LW 1/2

The new **wedge head design with AutoLock function** means greater construction safety. By turning the ledger the function gets activated and the wedge descends into rosette slot automatically. Thanks to the reduction of the wall thickness **there is a weight saving of 12%**. That leads to less strenuous working conditions. Additionally the **bending strength got increased about 24%**.

1/2

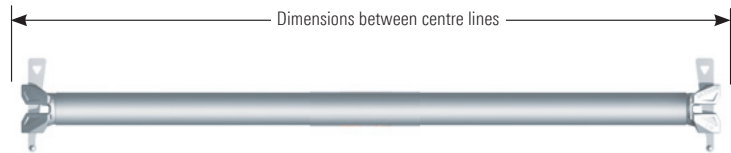

3



4

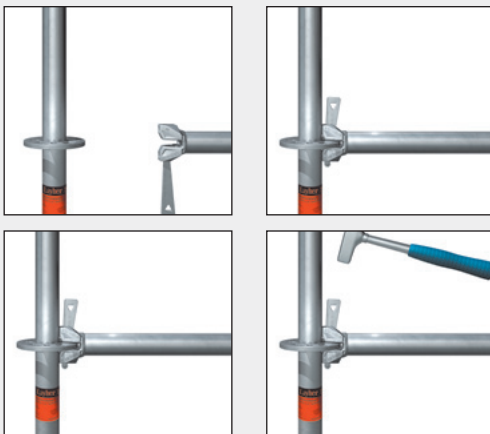

Pos.	Description	Dimensions L/H x W [m]	Weight approx. [kg]	PU [pcs.]	Ref. No.	
1	Allround O-ledger LW , with AutoLock function	0.39	1.9	250	2601.039	
		0.45	2.1	250	2601.045	
		0.73	2.9	400	2601.073	
		The 0.39 m ledger is used on the 0.39 m bracket for fall protection at the end.	0.86	3.3	50	2601.086
		The ledger 0.86 m is used for podia and stands.	0.90	3.4	50	2601.090
		It fits to the Event deck width EV 86.	1.04	3.8	50	2601.103
		The ledger 0.90 m is used for construction of the equalising modular stairway.	1.09	4.0	50	2601.109
		The 1.04 m ledger corresponds to half the 2.07 m bay.	1.29	4.6	50	2601.129
		The 1.29 m ledger corresponds to half the 2.57 m bay.	1.40	5.0	50	2601.140
			1.57	5.5	50	2601.157
		2.07	7.0	50	2601.207	
		2.57	8.5	50	2601.257	
		3.07	10.1	50	2601.307	
		4.14	13.4	50	2601.414	
		O-ledger, aluminium	0.73	2.3	400	3201.073
			1.09	2.8	50	3201.109
			1.40	3.7	50	3201.140
			1.57	4.0	50	3201.157
			2.07	4.5	50	3201.207
			2.57	4.9	50	3201.257
		3.07	5.5	50	3201.307	
2	Allround O-ledger LW , steel, metric with AutoLock function	0.25	1.4	300	2601.025	
		0.50	2.2	250	2601.050	
		1.00	3.7	50	2601.100	
		1.50	5.3	50	2601.150	
		2.00	6.8	50	2601.200	
		2.50	8.3	50	2601.250	
		3.00	9.9	50	2601.300	
3	Scaffolding tube , steel, hot-dip galvanized Scaffolding tubes dia. 48.3 x 4.0 mm, as per DIN EN 39	0.50	2.3	250	4600.050	
		1.00	4.5	61	4600.100	
		1.50	6.8	61	4600.150	
		2.00	9.0	61	4600.200	
		2.50	11.3	61	4600.250	
		3.00	13.5	61	4600.300	
		3.50	15.8	61	4600.350	
		4.00	16.7	61	4600.400	
		5.00	22.7	61	4600.500	
	6.00	25.0	61	4600.600		
4	U-ledger LW T14 , steel	0.45	2.1	250	2618.045	
		0.50	2.5	250	2618.050	
		0.73	3.1	400	2618.073	
		1.00	4.1	50	2618.100	
		1.04	4.2	50	2618.103	
		1.09	4.3	50	2618.109	
		1.29	5.2	50	2618.129	
		1.40	5.4	50	2618.139	
		U-ledger, aluminium	0.73	1.5	400	3203.073

WS = wrench size PU = packaging unit = available ex works = delivery time on request = only available in this packaging unit = the approval process is not yet completed

IND = Layher Individual possible – see page 7

Horizontal support elements, side protection

U-ledger deck configuration

Bay width Deck width	0.19 m		0.32 m		0.61 m	
	A	B	A	B	A	B
0.45 m	0	-	1	-	0	-
0.50 m	2	-	0	-	0	-
0.73 m	0	0	2	0	0	1
1.00 m	3	-	1	-	0	-
1.09 m	0	0	3	1	0	1
1.29 m	1	1	1	3	1	0
1.40 m	0	0	4	0	0	2
1.50 m	2	-	3	-	0	-
1.57 m	1	-	4	-	0	-
2.00 m	0	3	4	4	1	0
2.07 m	0	-	6	-	0	-
2.50 m	0	4	5	5	1	0
2.57 m	1	-	7	-	0	-
3.00 m	2	0	6	9	1	0
3.07 m	0	-	9	-	0	-

Example: A 1.09 m wide bay can be covered with 3x 0.32 m decks (Variant A) or 1x 0.61 m + 1x 0.32 m decks (Variant B).

Loading capacity U-ledger LW, steel*

Ledger type and length [m]	U-LW 0.73	U-LW 1.09	U-LW 1.40
Evenly distributed line load q [kN / m]	19.0	17.5	10.8
Individual load P in bay centre [kN]	6.1	8.6	6.4

Loading capacity U-ledger reinforced LW T14*

Length [m]	1.40	1.57	2.07	2.57	3.07
Evenly distributed line load q [kN / m]	19.8	17.7	13.0	8.4	5.0
Individual load P in bay centre [kN]	19.2	17.1	12.9	10.4	8.7

Loading capacity O-ledger reinforced LW*

Length [m]	1.09	1.40	1.57	2.07	2.57	3.07
Evenly distributed line load q [kN / m]	21.4	17.1	16.1	11.1	8.5	6.0
Individual load P in bay centre [kN]	19.6	19.4	17.3	13.2	10.7	9.0

* permissible working load

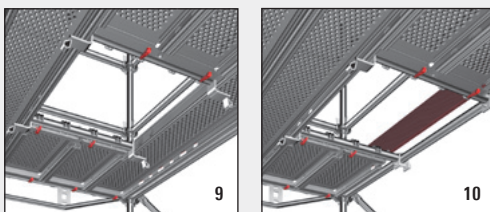

Openings, accesses and even conversions are easily constructed with **U- and O-ledgers 7-10** with lateral receiving elements.

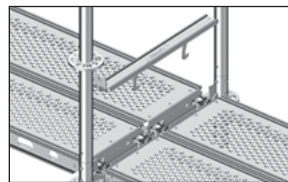
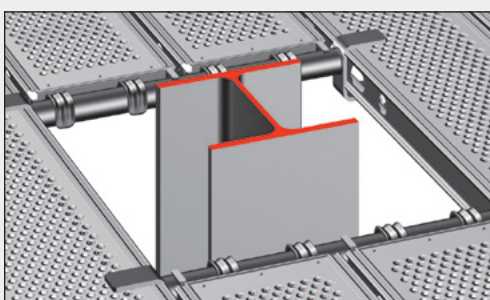

The **U-Lift-off preventer 3** is for U-ledgers, U-bridging ledgers, U-ledgers reinforced and U-lattice beams. It serves to prevent scaffolding decks from being lifted off.

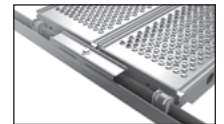
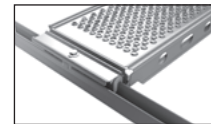
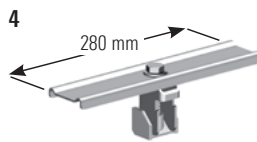

Securing of one deck

Securing of two deck

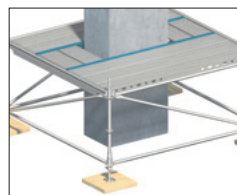

U-Version

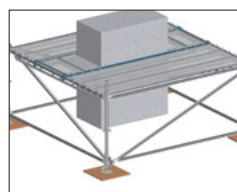

O-Version

The use of the interchangeable ledger in O-variant can be made by use of the Speedy Vario anchoring ledger LW (Ref. No. 1754.xxx). Learn more in the catalogue SpeedyScaf.



Pos.	Description	Dimensions L/H x W [m]	Weight approx. [kg]	PU [pcs.]	Ref. No.	
1	U-ledger reinforced LW T14, steel	1.40	8.9	50	2618.140	
		1.57	9.4	50	2618.157	
		2.07	12.7	50	2618.207	
		2.57	15.7	50	2618.257	
		3.07	19.0	50	2618.307	
	U-ledger reinforced LW T14, steel, metric	2.00	12.5	50	2618.200	
		2.50	15.5	50	2618.250	
		3.00	18.5	50	2618.300	
2a	U-bridging ledger, aluminium	1.57	4.3	25	3207.157	
		2.07	5.5	25	3207.207	
2b	U-ledger reinforced, aluminium	1.09	3.7	50	3203.109	
		1.40	4.5	50	3203.140	
3a	U-Lift-off preventer T8	0.39	0.6	250	2635.039	
		0.45	0.7	250	2635.045	
		0.50	0.8	250	2635.050	
		0.73	1.3	250	2635.073	
		1.00	1.7	50	2635.100	
		1.09	1.8	50	2635.109	
		1.29	2.1	50	2635.129	
3b	U-Lift-off preventer T9	1.40	5.3	50	2658.140	
		1.57	5.9	50	2658.157	
		2.07	7.9	50	2658.207	
		2.57	9.9	50	2658.257	
		3.07	11.9	50	2658.307	
4	Universal U-Lift-off preventer, usable for every U-section (steel and aluminium) and also in SpeedyScaf	WS 19	0.28	1.0	500	2635.000
		WS 22	0.28	1.0	250	2635.001
5	U-interchangeable ledger LW, steel, galvanized	0.73	2.9	100	2600.073	
		1.09	4.2	20	2600.109	
6	U-interchangeable ledger LW reinforced, steel, galvanized	1.40	8.7	50	2600.140	
		1.57	9.5	20	2600.157	
		2.07	12.5	20	2600.207	
		2.57	15.5	20	2600.257	
		3.07	18.5	20	2600.307	
7	U-ledger steel deck – steel deck, for connection on both sides to the steel deck flank, with securing flaps, loadable up to load class 3, up to steel decks of 3.07 m	0.32	3.1	100	2614.030	
		0.64	4.3	50	2614.073	
		0.96	5.5	50	2614.108	
8	U-ledger steel deck – O-ledger, one side for connection to the steel deck flank, with securing flap, the other side for connection to an O-ledger, with securing wedge	0.32	3.3	100	2614.001	
		0.64	4.4	50	2614.002	
		0.96	6.5	50	2614.004	
9	O-ledger steel deck – steel deck, for connection on both sides to the steel deck flank. with securing flaps. loadable up to load class 3. up to steel decks of 3.07 m	0.32	3.1	100	2614.069	
		0.64	4.2	50	2614.070	
		0.96	5.2	50	2614.071	
10	O-ledger steel deck – O-ledger, one side for connection to the steel deck flank, with securing flap, the other side for connection to an O-ledger, with securing wedge	0.32	2.4	100	2614.032	
		0.64	4.4	50	2614.064	
		0.96	5.5	50	2614.096	
11	Guardrail, adjustable for use in compensation bays	1.57 – 2.57	8.5	50	2606.000	
		1.09 – 1.57	5.7	50	2606.001	
12	O-bridging ledger LW, steel	1.09	5.9	50	2672.109	
		1.40	7.7	50	2672.140	
		1.57	8.7	50	2672.157	
		2.07	11.4	50	2672.207	
		2.57	14.3	50	2672.257	
		3.07	17.0	50	2672.307	

WS = wrench size PU = packaging unit = available ex works = delivery time on request = only available in this packaging unit = the approval process is not yet completed

IND = Layher Individual possible – see page 7

Diagonal bracing

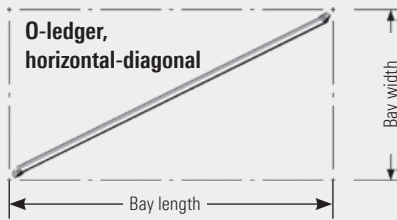

The **O-ledge, horizontal-diagonal 1**, with wedge heads serves to brace horizontal levels in scaffolding without standard decks or in scaffolding with board decking.

The **diagonal braces 2** with wedge locks further brace the basic system consisting of standards and ledgers, and thanks to their high connection values also facilitate special structures.

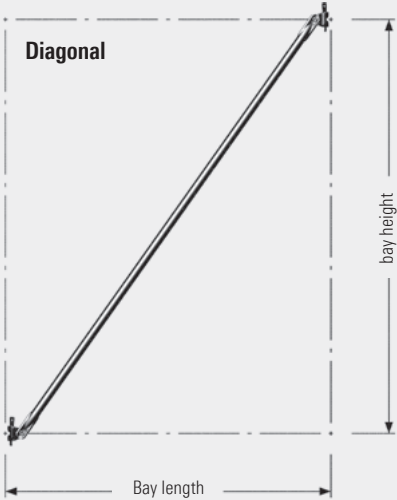

The bay length is displayed in numbers and by a defined colour code. Number of rosettes tell you which standard is used resp. the bay height.

1

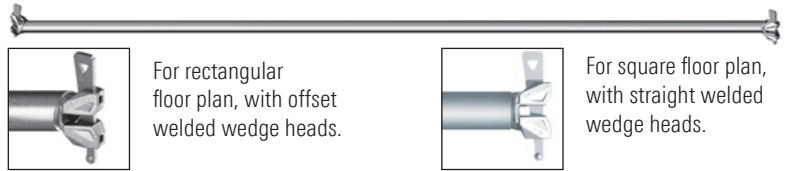

For rectangular floor plan, with offset welded wedge heads.

For square floor plan, with straight welded wedge heads.

Distinction between right and left horizontal diagonal brace

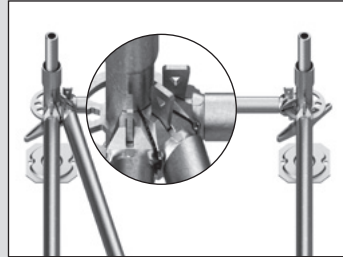

From top view, the wedge head of a left horizontal diagonal brace points to the left side.

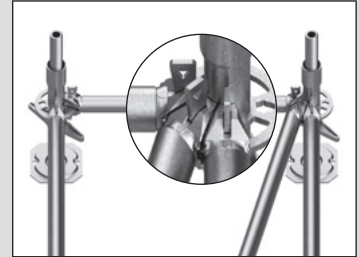

From top view, the wedge head of a right horizontal diagonal brace points to the right side.

2

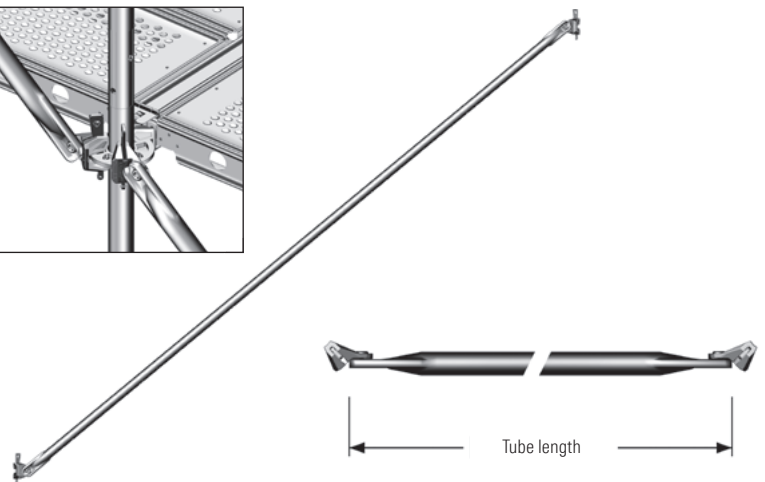
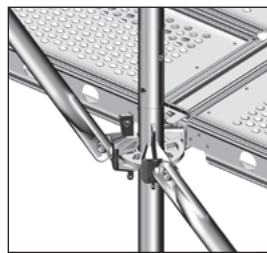

Pos.	Description	Direction	Dimensions L/H x W [m]	Weight approx. [kg]	PU [pcs.]	Ref. No.
1	O-ledge LW , horizontal-diagonal. steel for 1.09 m bay length, 1.09 m bay width for 1.29 m bay length, 1.29 m bay width for 1.57 m bay length, 1.09 m bay width for 1.57 m bay length, 1.57 m bay width for 2.00 m bay length, 1.00 m bay width for 2.00 m bay length, 2.00 m bay width for 2.07 m bay length, 0.73 m bay width for 2.07 m bay length, 1.04 m bay width for 2.07 m bay length, 1.09 m bay width for 2.07 m bay length, 1.57 m bay width for 2.07 m bay length, 2.07 m bay width for 2.07 m bay length, 0.73 m bay width for 2.57 m bay length, 1.09 m bay width for 2.57 m bay length, 1.57 m bay width for 2.57 m bay length, 2.07 m bay width for 2.57 m bay length, 2.57 m bay width for 2.57 m bay length, 0.73 m bay width for 3.07 m bay length, 0.73 m bay width for 3.07 m bay length, 1.09 m bay width for 3.07 m bay length, 3.07 m bay width for 3.07 m bay length, 3.07 m bay width		1.54	5.5	50	2678.109 🇩🇪
			1.82	6.5	50	2678.129 🇩🇪
		Right	1.91	6.7	50	2678.158 🇩🇪
			2.22	7.7	50	2678.157 🇩🇪
		Left	2.23	7.8	50	2678.201 🇩🇪
			2.83	9.6	50	2678.200 🇩🇪
		Left	2.19	7.8	50	2678.208 🇩🇪
		Left	2.32	8.1	50	2678.206 🇩🇪
		Right	2.34	8.1	50	2678.209 🇩🇪
		Left	2.60	9.2	50	2678.205 🇩🇪
			2.93	10.0	50	2678.207 🇩🇪
		Left	2.67	9.3	50	2678.258 🇩🇪
		Right	2.79	9.6	50	2678.259 🇩🇪
		Right	3.01	10.3	50	2678.256 🇩🇪
		Right	3.30	11.2	50	2678.255 🇩🇪
			3.64	12.2	50	2678.257 🇩🇪
		Left	3.16	10.9	50	2678.308 🇩🇪
		Right	3.26	11.1	50	2678.309 🇩🇪
			4.34	14.5	50	2678.307 🇩🇪

Pos.	Description	Dimensions L/H x W [m]	Weight approx. [kg]	PU [pcs.]	Ref. No.	
2	Diagonal brace LW, steel					
	0.73 m bay length	2.12	7.1	50	2683.073	
	1.04 m bay length	2.23	7.6	50	2683.104	
	1.09 m bay length	2.25	7.0	50	2683.109	
	1.29 m bay length	2.35	7.8	50	2683.129	
	1.40 m bay length	2.40	7.9	50	2683.140	
	1.57 m bay length	2.49	8.2	50	2683.157	
	2.07 m bay length	2.81	8.9	50	2683.207	
	2.57 m bay length	3.18	10.0	50	2683.257	
	3.07 m bay length	3.58	11.1	50	2683.307	
	4.14 m bay length	4.51	13.7	50	2683.414	
	0.73 m bay length	1.65	5.8	50	2682.073	
	1.04 m bay length	1.79	6.2	50	2682.104	
	1.09 m bay length	1.81	6.3	50	2682.109	
	1.29 m bay length	1.92	6.7	50	2682.129	
	1.40 m bay length	1.99	6.8	50	2682.140	
	1.57 m bay length	2.11	7.3	50	2682.157	
	2.07 m bay length	2.48	8.2	50	2682.207	
	2.57 m bay length	2.89	9.5	50	2682.257	
	3.07 m bay length	3.32	10.5	50	2682.307	
	0.73 m bay length	1.20	4.5	50	2681.073	
	1.04 m bay length	1.39	5.1	50	2681.104	
	1.09 m bay length	1.41	5.2	50	2681.109	
	1.29 m bay length	1.55	5.6	50	2681.129	
	1.40 m bay length	1.64	5.8	50	2681.140	
	1.57 m bay length	1.79	6.2	50	2681.157	
	2.07 m bay length	2.20	7.4	50	2681.207	
	2.57 m bay length	2.66	8.6	50	2681.257	
	3.07 m bay length	3.13	9.9	50	2681.307	
	0.73 m bay length	0.75	3.6	50	2680.073	
	1.04 m bay length	1.08	4.2	50	2680.104	
	1.09 m bay length	1.10	4.4	50	2680.109	
	1.29 m bay length	1.29	4.9	50	2680.129	
	1.40 m bay length	1.38	5.1	50	2680.140	
	1.57 m bay length	1.55	5.6	50	2680.157	
	2.07 m bay length	2.03	6.9	50	2680.207	
	2.57 m bay length	2.51	8.2	50	2680.257	
	3.07 m bay length	3.00	9.6	50	2680.307	
		Diagonal brace, aluminium				
		0.73 m bay length	2.12	3.9	50	3204.073
		1.09 m bay length	2.25	4.1	50	3204.109
		1.40 m bay length	2.40	4.2	50	3204.140
		1.57 m bay length	2.49	4.3	50	3204.157
		2.07 m bay length	2.81	4.7	50	3204.207
		2.57 m bay length	3.18	4.9	50	3204.257
	3.07 m bay length	3.58	5.3	50	3204.307	
	Diagonal brace metric LW, steel					
	1.00 m bay length	2.22	7.3	50	2683.100	
	2.00 m bay length	2.76	8.8	50	2683.200	
	2.50 m bay length	3.12	9.9	50	2683.250	
	3.00 m bay length	3.52	11.0	50	2683.300	
	1.00 m bay length	1.77	6.2	50	2682.100	
	2.00 m bay length	2.42	8.0	50	2682.200	
	2.50 m bay length	2.83	9.0	50	2682.250	
	3.00 m bay length	3.26	10.3	50	2682.300	
	1.00 m bay length	1.36	5.0	50	2681.100	
	2.00 m bay length	2.14	7.2	50	2681.200	
	2.50 m bay length	2.59	8.5	50	2681.250	
	3.00 m bay length	3.06	9.7	50	2681.300	
	1.00 m bay length	1.03	4.0	50	2680.100	
	2.00 m bay length	1.96	6.7	50	2680.200	
	2.50 m bay length	2.44	8.1	50	2680.250	
	3.00 m bay length	2.93	9.4	50	2680.300	

WS = wrench size PU = packaging unit = available ex works = delivery time on request = only available in this packaging unit = the approval process is not yet completed

IND = Layher Individual possible – see page 7

Scaffolding decks, U-suspension

Our scaffolding decks comply with the requirements of DIN EN 12811.

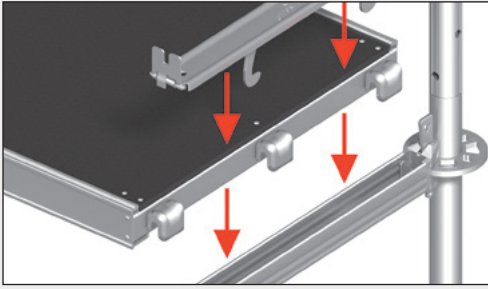

U-suspension

In the Layher system, depending on the type of application and scaffolding group but also in accordance with your working requirements and priorities, choose from decks made of hot-dip galvanized steel, aluminium, or an aluminium frame with plywood or plastic board. The load-bearing capacity of the overall system must be observed. The claws of the Layher scaffolding decks slide easily during assembly into the U-/O-sections of the transverse ledgers, ensuring unbeatable speed of assembly. Decks with round ledger supports are especially suitable for abrasive-blasting work in order to avoid blasting residue deposits.

The **steel deck LW 1** fulfils the same load-bearing capacities as the proven **steel deck T4 2** with a considerably lower weight thanks to the use of high-tensile steel and intelligent combination of perforation and profiling.

The **U-Xtra-N deck 4** is identical in construction with the robust deck, but is equipped with a glass-fibre-reinforced plastic plate. It is very weather-resistant: No rotting, no fungus growth, no split-open rivet holes. The breaking load of the plastic plate is about 3 times that of dry plywood. The surface has a proven anti-slip structure, which is very easy to clean. Plaster and dirt can be easily removed by using a high-pressure cleaner or a scraper.

Thanks to optimization of the cap of the **steel deck T4/LW**, precision-fit decking above the rosette is possible.

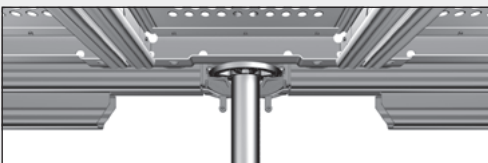

The **stalu deck 5-7**, is an extremely lightweight and durable aluminium deck with a sturdy, riveted steel cap.

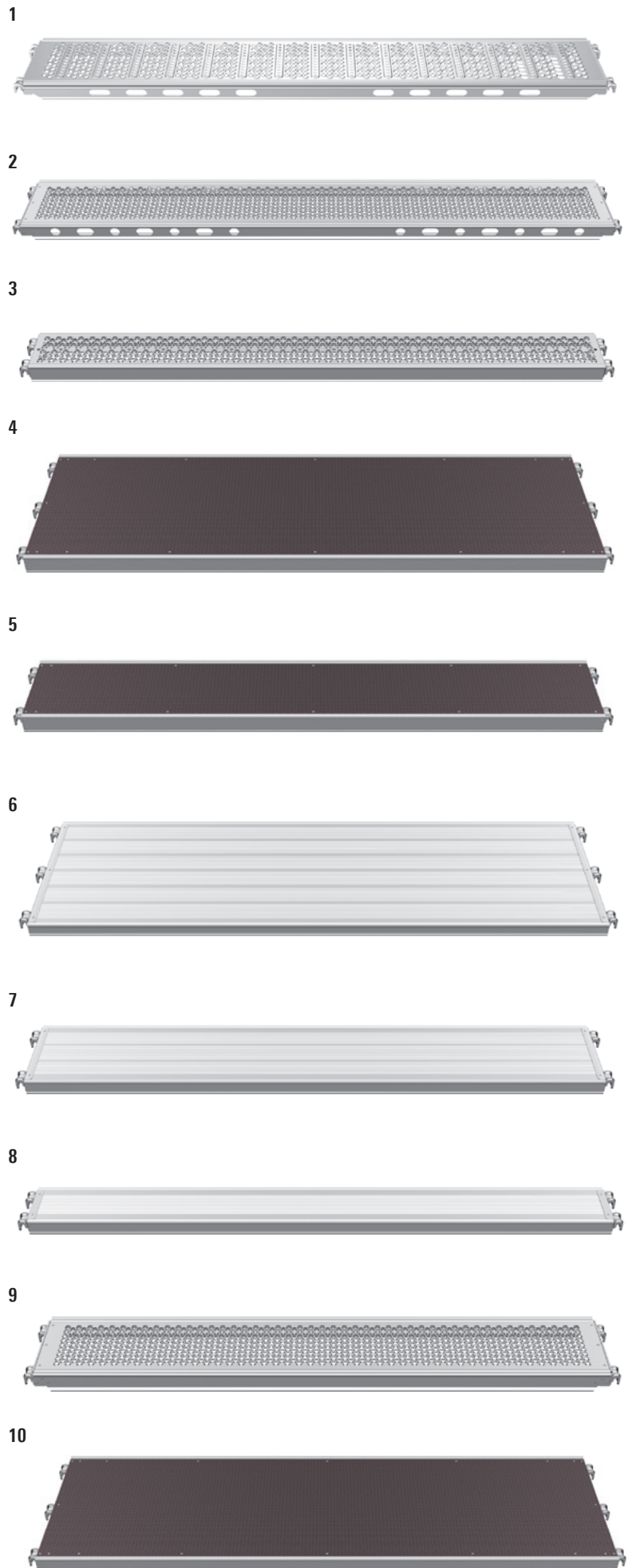

Pos.	Description	Use up to load class	Dimensions L/H x W [m]	Weight approx. [kg]	PU [pcs.]	Ref. No.	
1	U-steel deck LW, 0.32 m wide steel, hot-dip galvanized perforated, non-slip working surface	IND	6	0.73 x 0.32	5.6	60	3883.073
			6	1.00 x 0.32	7.2	60	3883.100
			6	1.04 x 0.32	7.4	60	3883.104
			6	1.09 x 0.32	7.7	60	3883.109
			6	1.29 x 0.32	8.6	60	3883.129
			6	1.40 x 0.32	9.4	60	3883.140
			6	1.57 x 0.32	10.5	60	3883.157
			6	2.07 x 0.32	13.4	60	3883.207
			5	2.57 x 0.32	16.4	60	3883.257
			4	3.07 x 0.32	19.3	60	3883.307
2	U-steel deck T4, 0.32 m wide steel, hot-dip galvanized perforated, non-slip working surface	IND	6	0.73 x 0.32	6.0	60	3812.073
			6	1.09 x 0.32	8.3	60	3812.109
			6	1.40 x 0.32	10.6	60	3802.140
			6	1.57 x 0.32	11.6	60	3812.157
			6	2.07 x 0.32	14.9	60	3812.207
			5	2.57 x 0.32	18.2	60	3812.257
			4	3.07 x 0.32	21.5	60	3812.307
3	U-steel deck, 0.19 m wide constructed as 3812 as equalizing deck, e.g. for birdcage scaffolding	IND	6	0.73 x 0.19	5.1	50	3801.073
			6	1.09 x 0.19	6.4	50	3801.109
			6	1.29 x 0.19	7.4	50	3801.129
			6	1.40 x 0.19	8.0	50	3801.140
			6	1.57 x 0.19	8.5	50	3801.157
			6	2.07 x 0.19	10.2	50	3801.207
			5	2.57 x 0.19	13.2	50	3801.257
4	U-Xtra-N deck, 0.61 m wide Aluminium stile section, glass-fibre-reinforced plastic plate extremely durable, lightweight, non-slip working surface	IND	3	0.73 x 0.61	7.0	60	3866.073
			3	1.09 x 0.61	9.5	60	3866.109
			3	1.57 x 0.61	13.0	40	3866.157
			3	2.07 x 0.61	16.2	40	3866.207
			3	2.57 x 0.61	19.0	40	3866.257
			3	3.07 x 0.61	23.5	40	3866.307
5	U-Xtra-N deck, 0.32 m wide constructed as Ref. No. 3866 as console or equalizing deck, e.g. for birdcage scaffolding	IND	6	1.57 x 0.32	8.5	30	3877.157
			5	2.07 x 0.32	10.7	30	3877.207
			4	2.57 x 0.32	13.0	30	3877.257
			3	3.07 x 0.32	15.2	30	3877.307
6	U-stalu deck T9, 0.61 m wide extremely lightweight aluminium deck with sturdy, riveted steel caps, stacking height only 54 mm	IND	6	0.73 x 0.61	6.6	40	3867.073
			6	1.09 x 0.61	8.8	40	3867.109
			6	1.57 x 0.61	11.7	40	3867.157
			6	2.07 x 0.61	14.8	40	3867.207
			5	2.57 x 0.61	17.9	40	3867.257
7	U-stalu deck T9, 0.32 m wide constructed as 3867 as equalizing deck, e.g. for birdcage scaffolding	IND	6	1.57 x 0.32	7.4	30	3856.157
			6	2.07 x 0.32	9.2	30	3856.207
			5	2.57 x 0.32	11.0	30	3856.257
			4	3.07 x 0.32	13.3	30	3856.307
8	U-stalu deck T9, 0.19 m wide constructed as 3867 as equalizing deck, e.g. for birdcage scaffolding	IND	6	1.57 x 0.19	5.6	50	3857.157
			6	2.07 x 0.19	7.2	50	3857.207
			5	2.57 x 0.19	8.7	50	3857.257
			4	3.07 x 0.19	10.2	50	3857.307
9	U-alu deck, perforated, 0.32 m wide Deck and caps of aluminium with robust steel claws perforated, non-slip working surface	IND	6	0.73 x 0.32	3.1	60	3803.073
			6	1.09 x 0.32	4.4	60	3803.109
			6	1.57 x 0.32	6.5	60	3803.157
			5	2.07 x 0.32	8.0	60	3803.207
			4	2.57 x 0.32	10.0	60	3803.257
10	U-robust deck, 0.61 m wide Aluminium stile section, plywood panel BFU 100G phenolic resin coating and rot protection; lightweight, non-slip, easily stackable	IND	3	1.57 x 0.61	13.1	40	3835.157
			3	2.07 x 0.61	16.4	40	3835.207
			3	2.57 x 0.61	19.3	40	3835.257
			3	3.07 x 0.61	24.2	40	3835.307

WS = wrench size PU = packaging unit = available ex works = delivery time on request = only available in this packaging unit = the approval process is not yet completed

IND = Layher Individual possible – see page 7

Access decks, corner-decks, U-suspension

Internal accesses can be built into the scaffolding with the **access decks**. These decks conform to the requirements of DIN EN 12811 and are available with a separate or an integrated access ladder for internal access.



In the case of circular scaffolding, the corners are covered with the **U-corner deck, adjustable, with toe board 6a**. System-conforming covers are thus no longer a problem. You obtain a continuous walk surface with integrated toe board.

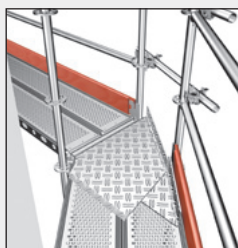

Installation situation 45° **7a**

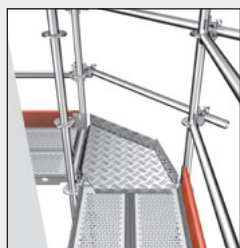

Installation situation 90° **7a**

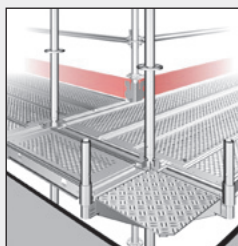

Installation situation 90° **7c**

The **access ladder 9**, 7-rungs is a flexible aid to climbing inside the scaffolding to a storey height of 2 m.

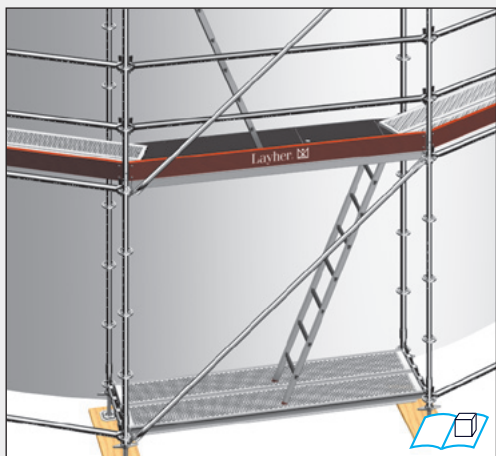

Installation situation U-robust access deck with hatch offset **10**

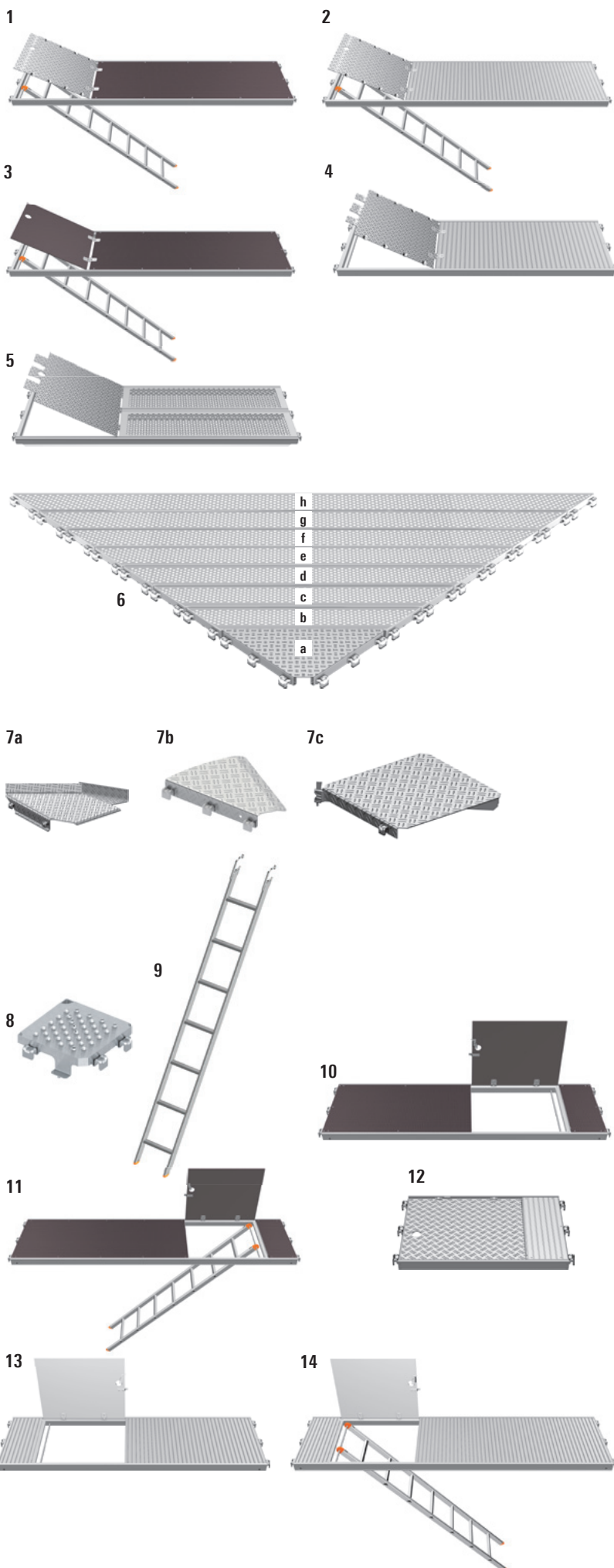

Pos.	Description	Use up to load class	Dimensions L/H x W [m]	Weight approx. [kg]	PU [pcs.]	Ref. No.	
1	U-Xtra-N hatch-type access deck 0.61 m wide, with integrated access ladder, deck surface of glass-fibre-reinforced plastic, aluminium access hatch	IND	3	2.57 x 0.61	25.4	40	3869.257
			3	3.07 x 0.61	29.5	40	3869.307
2	U-aluminium access deck, 0.61 m wide, with integrated access ladder lightweight access deck with aluminium deck surface and aluminium access hatch	IND	3	2.57 x 0.61	24.0	40	3852.257
			3	3.07 x 0.61	28.0	40	3852.307
3	U-robust access deck, 0.61 m wide, with integrated access ladder	IND	3	2.57 x 0.61	24.0	40	3838.257
			3	3.07 x 0.61	27.4	40	3838.307
4	U-aluminium access deck, 0.61 m wide lightweight access deck with aluminium deck surface and aluminium access hatch	IND	3	1.57 x 0.61	15.1	40	3851.157 📦
			3	2.07 x 0.61	17.0	40	3851.207
			3	2.57 x 0.61	20.0	40	3851.257
			3	3.07 x 0.61	24.5	40	3851.307
5	U-access deck, steel, 0.64 m wide aluminium access hatch		4	2.07 x 0.64	28.9	30	3813.207 📦
			4	2.57 x 0.64	38.0	30	3813.257 📦
6	U-corner deck Ⓢ type a		3	0.80 x 0.35	8.6	50	3868.101 ⌚
	U-steel deck 45° Ⓢ type b		3	1.17 x 0.19	6.4	50	3868.102 ⌚
	type c		3	1.56 x 0.19	7.9	50	3868.103 ⌚
	type d		3	1.94 x 0.19	9.7	50	3868.104 ⌚
	type e		3	2.33 x 0.19	11.5	50	3868.105 ⌚
	type f		3	2.71 x 0.19	13.3	50	3868.106 ⌚
	type g		3	3.09 x 0.19	16.8	50	3868.107 ⌚
	type h		3	3.48 x 0.19	18.6	50	3868.108 ⌚
7a	Corner deck, adjustable, for angles from 45° – 90°, with toe board, steel		3	0.61	21.5	30	3819.000 📦
7b	U-corner deck for circular scaffolding 30°, steel			0.73	8.5	120	3868.000 📦
7c	U-corner deck Ⓢ, steel for 0.36 m wide scaffolding for 0.73 m wide scaffolding		3	0.36 x 0.36	6.4	50	2630.037 📦
			3	0.73 x 0.73	20.8	30	2630.070 📦
8	U-console corner deck Ⓢ			0.19 x 0.19	2.1	10	3868.319 📦
				0.32 x 0.32	3.7	10	3868.332 📦
9	Access ladder, T19, steel, 7 rungs, for access deck Ref. No. 3813, Ref. No. 3851, and Ref. No. 3858			2.15 x 0.35	7.6	70	4009.007
10	U-robust access deck, 0.61 m wide, hatch offset without ladder. For use with pos. 9	IND	3	1.57 x 0.61	14.2	40	3858.157 📦
			3	2.07 x 0.61	17.2	40	3858.207 📦
11	U-robust access deck, 0.61 m wide, hatch offset, with integrated access ladder	IND	3	2.57 x 0.61	25.2	40	3859.257 📦
			3	3.07 x 0.61	28.4	40	3859.307 📦
12	U-access deck, aluminium, 0.61 m wide, without ladder. For use with pos. 9		3	1.00 x 0.61	10.0	40	3851.100 ⌚
13	U-aluminium access deck, 0.61 m wide, hatch offset without ladder. For use with pos. 9	IND	3	2.07 x 0.61	17.6	40	3875.207 ⌚
14	U-aluminium access deck, 0.61 wide, hatch offset, with integrated access ladder	IND	3	2.57 x 0.61	25.0	40	3875.257 ⌚
			3	3.07 x 0.61	29.0	40	3875.307 ⌚

WS = wrench size PU = packaging unit 📦 = available ex works ⌚ = delivery time on request 📦 = only available in this packaging unit Ⓢ = the approval process is not yet completed

IND = Layher Individual possible – see page 7

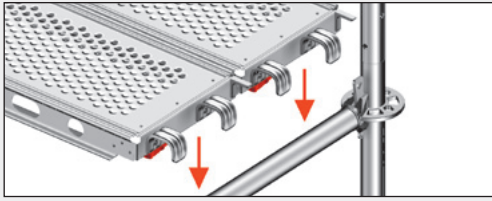

O-suspension

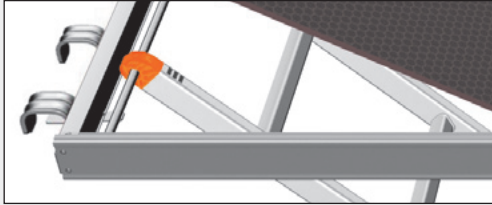

Individual stamping

The Layher steel decks can be provided with individual lettering. Conspicuously visible on the side section, they give the Layher steel deck that certain something.



Similar to the steel decks, also the Stalu, Xtra-N and robust decks can be individualized. The stamping is particularly high-quality. The needle stamping process provides fine and very precise lettering.

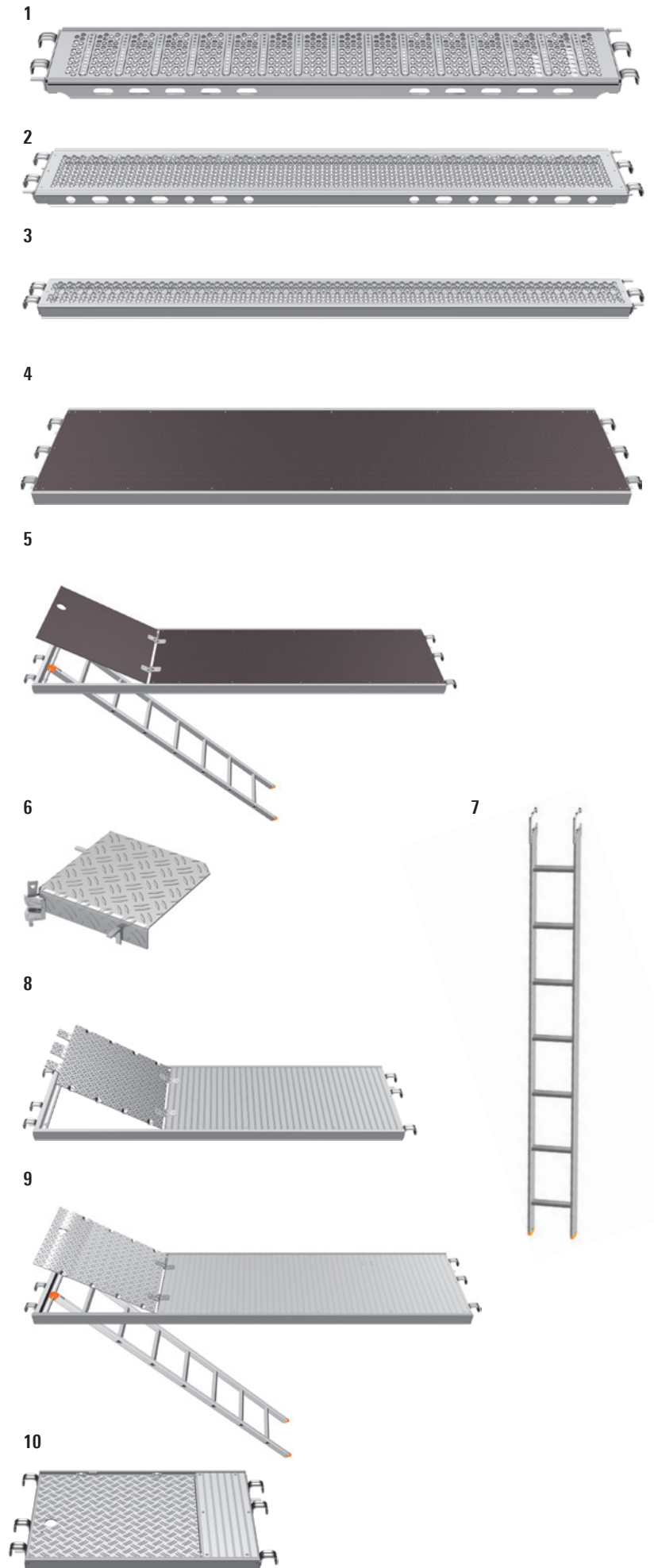

Pos.	Description	Use up to load class	Dimensions L/H x W [m]	Weight approx. [kg]	PU [pcs.]	Ref. No.	
1	O-steel deck LW, 0.32 m wide steel, hot-dip galvanized; with integrated lift-off and tilt preventer, perforated, non-slip working surface	IND	6	0.73 x 0.32	6.4	30	3890.073
			6	1.09 x 0.32	8.5	30	3890.109
			6	1.29 x 0.32	9.3	30	3890.129
			6	1.40 x 0.32	10.1	30	3890.140
			6	1.57 x 0.32	11.3	30	3890.157
			6	2.07 x 0.32	14.2	30	3890.207
			5	2.57 x 0.32	17.2	30	3890.257
			4	3.07 x 0.32	20.1	30	3890.307
2	O-steel deck T9, 0.32 m wide steel, hot-dip galvanized; with integrated swivelling lift-off and tilt preventer, perforated, non-slip working surface	IND	6	0.73 x 0.32	6.8	30	3862.073
			6	1.09 x 0.32	9.1	30	3862.109
			6	1.40 x 0.32	10.8	30	3862.140
			6	1.57 x 0.32	12.4	30	3862.157
			6	2.07 x 0.32	15.7	30	3862.207
			5	2.57 x 0.32	19.0	30	3862.257
			4	3.07 x 0.32	22.3	30	3862.307
			3	O-steel deck T9, 0.19 m wide steel, hot-dip galvanized; with integrated swivelling lift-off and tilt preventer, perforated, non-slip working surface	IND	6	0.73 x 0.19
6	1.09 x 0.19	7.0				50	3863.109
6	1.40 x 0.19	9.0				50	3863.140
6	1.57 x 0.19	8.4				50	3863.157
6	2.07 x 0.19	10.7				50	3863.207
5	2.57 x 0.19	13.0				50	3863.257
4	3.07 x 0.19	18.2				50	3863.307
4	O-robust deck T9, 0.61 m wide aluminium stile section, plywood panel BFU 100G phenolic resin coating and rot protection; lightweight, non-slip, easily stackable	IND				3	0.73 x 0.61
			3	1.09 x 0.61	11.2	60	3870.109
			3	1.57 x 0.61	14.6	40	3870.157
			3	2.07 x 0.61	17.9	40	3870.207
			3	2.57 x 0.61	21.9	40	3870.257
			3	3.07 x 0.61	26.5	40	3870.307
			5	O-robust access deck T9, 0.61 m wide , with integrated access ladder	IND	3	2.57 x 0.61
3	3.07 x 0.61	29.7				40	3872.307
6	U-corner deck , steel for 0.36 m wide scaffolding		3	0.34 x 0.34	6.9	50	2630.040
7	Access ladder , T15, steel, 7 rungs for access deck Ref. No. 3871			2.15 x 0.35	7.6	70	4009.007
8	O-access deck T9 , aluminium 0.61 m wide easy access with aluminium deck surface and aluminium access hatch	IND	3	1.57 x 0.61	14.9	40	3871.157
			3	2.07 x 0.61	17.9	40	3871.207
9	O-access deck , aluminium, 0.61 m wide with integrated access ladder	IND	3	2.57 x 0.61	26.5	40	3874.257
10	O-access deck , aluminium, 0.61 m wide	IND	3	1.00 x 0.61	10.0	40	3871.100

WS = wrench size PU = packaging unit = available ex works = delivery time on request = only available in this packaging unit = the approval process is not yet completed



IND = Layher Individual possible – see page 7

Steel plank, gap decks

The **steel plank 1/2** is a very safe bridging element capable of bearing high loads for all scaffolding systems. It is preferred to wooden planks for use in areas with stringent fire protection requirements.

- ▶ Long service life, reusable
- ▶ Lower weight compared with wooden planks
- ▶ Non-slip and non-inflammable
- ▶ If at least 2 steel planks are adjacent to one another, they may also be used in brick guards.

The support length must be at least 10 cm at every support.

 Scaffolding planks can be found in the catalogue for System-free Accessories. 

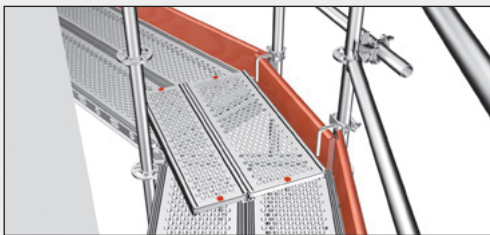

Every plank has to be secured at every bearing point with two locking pins against slipping and lifting-off. If **securing screws 4a** are used, one screw per end is enough.

Gap covers

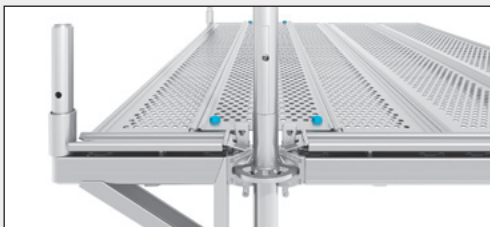

The **steel gap sheet 5** can be used between two scaffolding decks on SpeedyScaf and Allround Scaffolding. For use on gap widths up to 20 cm.

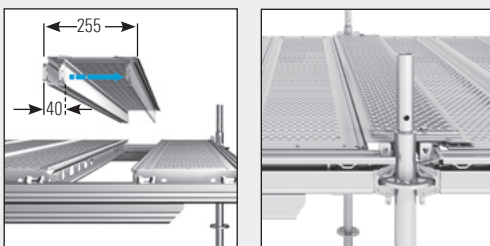

For closing of system caused gaps the **telescopic gap deck 7** can be used. Even with mounted ledgers, it is possible to create a closed decking over the rosette.

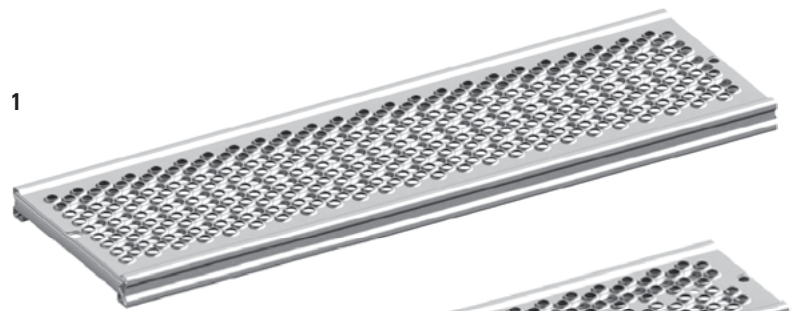

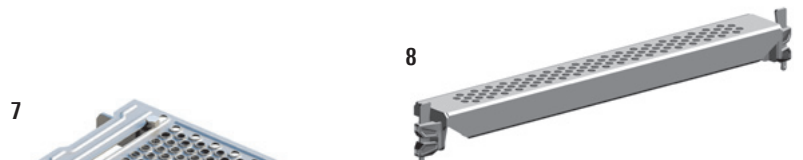
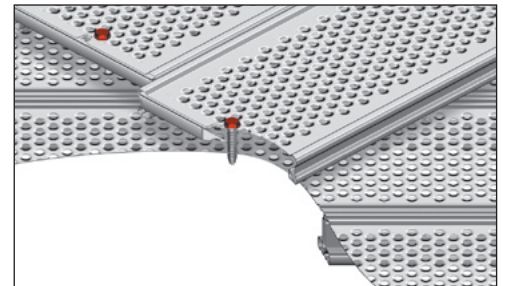

4a/b

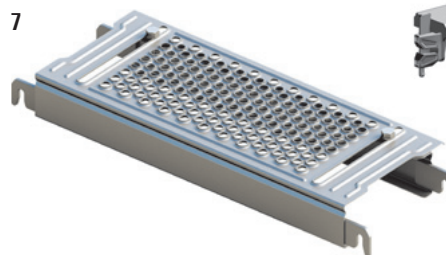

8



 More information about the telescopic gap deck: yt-spaltboden-en.layher.com 

Pos.	Description	Use up to load class	Dimensions L/H x W [m]	Weight approx. [kg]	PU [pcs.]	Ref. No.
1	Steel plank, 0.30 m system-free, completely made of hot-dip galvanized steel	6	1.00 x 0.30	6.5	30	3880.100
		6	1.50 x 0.30	10.3	30	3880.150
		5	2.00 x 0.30	12.8	30	3880.200
		3	2.50 x 0.30	15.3	30	3880.250
2	Steel plank, 0.20 m system-free, completely made of hot-dip galvanized steel	6	1.00 x 0.20	4.8	100	3878.100
		6	1.50 x 0.20	7.2	100	3878.150
		5	2.00 x 0.20	9.5	100	3878.200
		3	2.50 x 0.20	11.8	100	3878.250
3	Locking pin for steel plank, dia. 11 mm not for multiple use		0.08	0.5	100	3800.013
4a	Securing screw, long (red), steel, galvanized For securing of steel planks on steel decks	WS 19	0.08 x 0.03	4.0	50	3800.016
		WS 22	0.08 x 0.03	3.9	50	3800.017
4b	Securing screw, short (blue), steel, galvanized For securing of steel gap sheet on steel decks	WS 19	0.04 x 0.02	2.3	50	3800.018
		WS 22	0.04 x 0.02	2.3	50	3800.019
5	Steel gap sheet, 0.32 m Use up to load class 6 with maximum gap widths of 20 cm for 0.73 m bay length for 1.09 m bay length for 1.57 m bay length for 2.07 m bay length for 2.57 m bay length for 3.07 m bay length	6		2.6	150	3881.000
		6		3.8	150	3881.001
		6		4.2	100	3881.002
		6		6.3	100	3881.003
		6		8.5	100	3881.004
		6		12.0	100	3881.005
6	U gap sheet, with hooks, 0.32 m for 1.57 m bay length for 2.07 m bay length for 2.57 m bay length for 3.07 m bay length			4.5	100	3882.157
				6.6	100	3882.207
				8.8	100	3882.257
				12.3	100	3882.307
7	Telescopic U-gap deck for closing gaps from 40 to 255 mm, continuously adjustable	6	1.57	11.4	40	3881.157
		6	2.07	14.9	40	3881.207
		5	2.57	18.6	40	3881.257
		4	3.07	22.3	40	3881.307
8	U-gap deck, 0.11 m with wedge heads		0.73	4.5	150	2602.073
			1.09	5.9	50	2602.109
			1.40	6.9	50	2602.140
			1.57	7.8	50	2602.157
			2.07	8.5	50	2602.207
			2.57	10.1	50	2602.257
	3.07	13.5	50	2602.307		

WS = wrench size PU = packaging unit = available ex works = delivery time on request = only available in this packaging unit = the approval process is not yet completed

= Layher Individual possible – see page 7

Toe boards

The **O-board bearer 1** is used to provide trip-proof decking surfaces with boards. For use of scaffolding boards see DIN 4420. Accesses with O-decks can also be provided.

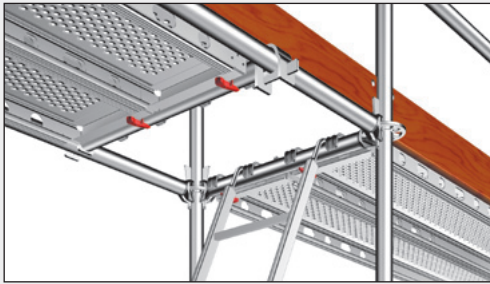

The **U-ledger LW 0.73 m, 15° – 44°, 19 WS 4** permits low angles in large circular scaffolding structures.

The three-part side protection in the scaffolding bay and at the ends of the scaffolding is completed with **toe boards**. The fitting is positioned between vertical standard and wedge.

Individual toe boards

From a minimum order quantity of 500 pcs. the toe boards can be individually designed in printing and painting. Further information can be found in the Layher Info "Layher Individual".



The **O-/U-steel toe board 7/8** reduces the fire risk. The offset fittings permit a gap-free transition from the deck to the toe board. It features high stiffness and is easy to stack.

The **O-/U-toe board, aluminium 9/10** is the light-weight alternative and can also be used in the case of special fire protection requirements.

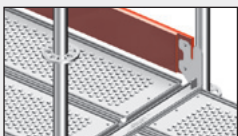

Assembly of the wooden toe board

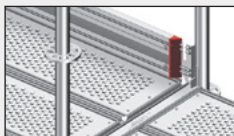

Assembly of the steel toe board

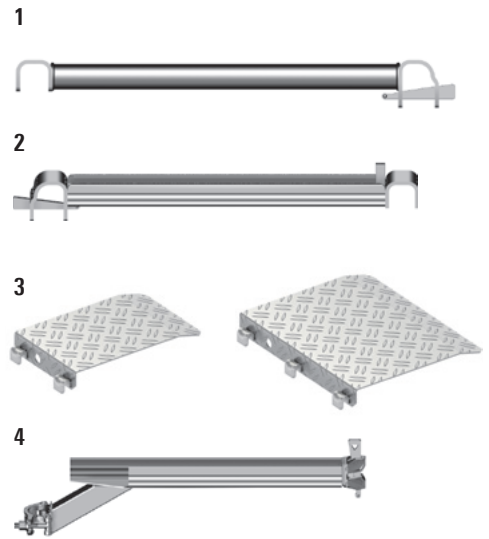

Advantages:

- ▶ Reduction of fire risk
- ▶ High stiffness and sturdiness
- ▶ Easy stacking of the toe boards
- ▶ No gap between toe board and deck

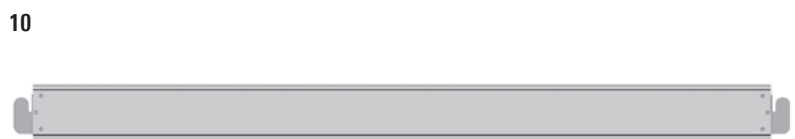

Pos.	Description	Dimensions L/H x W [m]	Weight approx. [kg]	PU [pcs.]	Ref. No.	
1	O-board bearer steel	0.73	3.7	50	2615.073	
		1.09	4.6	50	2615.109	
		1.40	5.3	50	2615.140	
		1.57	7.4	50	2615.157	
		2.07	10.3	50	2615.207	
		2.57	12.5	50	2615.257	
		3.07	15.0	50	2615.307	
2	U-board bearer, 0.73 m	0.73	3.6	50	2615.000	
3	U-deck for equalisation bay	0.50 x 0.19	4.3	50	3868.019	
		0.50 x 0.32	7.2	100	3868.032	
		0.50 x 0.61	13.8	100	3868.061	
4	U-ledger LW, 0.73 m, 15° – 44°, WS 19	0.73	3.6	100	2618.000	
5	U-toe board, wood for decks with U-insertion. for longitudinal and end sides	IND	0.73 x 0.15	1.5	140	2640.073
			1.09 x 0.15	2.5	140	2640.109
			1.40 x 0.15	3.5	140	2640.140
			1.57 x 0.15	3.5	140	2640.157
			2.07 x 0.15	4.6	140	2640.207
			2.57 x 0.15	5.7	140	2640.257
			3.07 x 0.15	7.1	140	2640.307
4.14 x 0.15	7.5	140	2640.414			
6	O-toe board, wood for decks with O-insertion. for longitudinal and end sides	IND	0.73 x 0.15	1.5	140	2642.073
			1.09 x 0.15	2.5	140	2642.109
			1.40 x 0.15	3.4	140	2642.140
			1.57 x 0.15	3.5	140	2642.157
			2.07 x 0.15	4.3	140	2642.207
			2.57 x 0.15	5.7	140	2642.257
			3.07 x 0.15	6.3	140	2642.307
7	U-steel toe board T18	0.73 x 0.15	1.8	280	2644.073	
		1.09 x 0.15	2.5	140	2644.109	
		1.40 x 0.15	3.1	140	2644.140	
		1.57 x 0.15	3.4	140	2644.157	
		2.07 x 0.15	4.4	140	2644.207	
		2.57 x 0.15	5.4	140	2644.257	
		3.07 x 0.15	6.3	140	2644.307	
8	O-steel toe board T18	0.73 x 0.15	1.7	280	2643.073	
		1.09 x 0.15	2.4	140	2643.109	
		1.40 x 0.15	3.0	140	2643.140	
		1.57 x 0.15	3.3	140	2643.157	
		2.07 x 0.15	4.3	140	2643.207	
		2.57 x 0.15	5.3	140	2643.257	
		3.07 x 0.15	6.2	140	2643.307	
9	U-toe board, aluminium for longitudinal and end sides, lightweight and durable	0.73 x 0.15	1.5	210	2651.073	
		1.09 x 0.15	2.2	210	2651.109	
		1.40 x 0.15	2.9	210	2651.140	
		1.57 x 0.15	3.1	210	2651.157	
		2.07 x 0.15	3.7	210	2651.207	
		2.57 x 0.15	4.7	210	2651.257	
		3.07 x 0.15	5.7	210	2651.307	
10	O-toe board, aluminium for longitudinal and end sides, lightweight and durable	0.73 x 0.15	1.5	210	2641.073	
		1.09 x 0.15	1.7	210	2641.109	
		1.40 x 0.15	2.9	70	2641.140	
		1.57 x 0.15	3.1	210	2641.157	
		2.07 x 0.15	3.3	210	2641.207	
		2.57 x 0.15	4.1	210	2641.257	
3.07 x 0.15	4.9	210	2641.307			
11	Half-coupler with toe board pin	WS 19		1.0	25	4708.019
		WS 22		1.0	25	4708.022

WS = wrench size PU = packaging unit = available ex works = delivery time on request = only available in this packaging unit = the approval process is not yet completed

IND = Layher Individual possible – see page 7

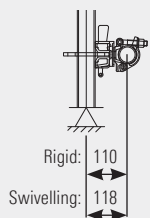

The **wedge head coupler 1/2** serves to connect 48.3 mm dia. scaffolding tubes to the rosettes of the standards.

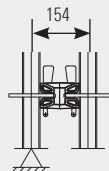

The **twin wedge coupler 3** is for connecting several standards to each other, e.g. for combining standards in support scaffolding construction.

Scaffolding couplers 4/5 connections, in steel, drop-forged; as per DIN EN 74-1. Tightening torque of collar nuts 50 Nm.

i

Further scaffolding couplers can be found in the catalogue for System-free Accessories

Scaffolding must be anchored vertically to and parallel with the facade with resistance to both tensile and compressive stress. The **Allround wall tie 0.80 m 8** must be secured with a standard coupler to the standard and supported with the fork plate on the U-section of the transverse ledger.

1



2

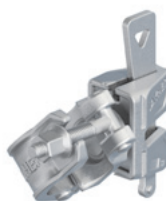

3



4a/b



5a/b

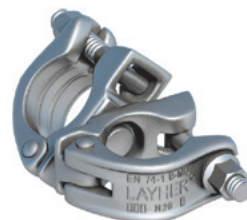

For right-angled connection of tubes with dia. 48.3 mm.

For connection at any angle of tubes with dia. 48.3 mm.

6



7



8



9



10



11



12



By using the **scaffolding lock**, you can secure your scaffolding against unauthorized alteration or dismantling. Use in topmost level instead of locking pins.

Pos.	Description	Dimensions L/H x W [m]	Weight approx. [kg]	PU [pcs.]	Ref. No.	
1	Wedge-head coupler, rigid	WS 19		1.1	25	2628.019
		WS 22		1.1	25	2628.022
2	Wedge-head coupler, swivelling	WS 19		1.5	25	2629.019
		WS 22		1.5	25	2629.022
3	Twin wedge coupler			1.2	25	2629.000
4a	Double coupler Class BB. EN 74-1 RA BB C3 M, quality-monitored, for use in class B and BB on steel and aluminium tube	WS 19		1.3	25	4700.019
		WS 22		1.3	25	4700.022
4b	Rapid double coupler Description as Pos. 4a acc. to approval Z-8.331-947	WS 19		1.3	25	4777.019
		WS 22		1.3	25	4777.022
5a	Swivel coupler Class B. EN 74-1 SW B C3 M, quality-monitored, for use in class B on steel and aluminium tube	WS 19		1.5	25	4702.019
		WS 22		1.5	25	4702.022
5b	Rapid swivel coupler Description as Pos. 5a acc. to approval Z-8.331-947	WS 19		1.5	25	4778.019
		WS 22		1.5	25	4778.022
6	Allround rosette cover without connected ledger Polyethylene, fixing with disposable tie			0.7	10	4007.012
7	Allround rosette cover without connected ledger Polyethylene, fixing with disposable tie			0.9	10	4007.013
8	Allround wall tie, 0.80 m	0.80		3.3	100	2639.080
9	Wall tie	0.38		1.6	250	1754.038
		0.69		2.8	50	1754.069
		0.95		3.7	50	1754.095
		1.45		5.7	50	1754.145
		1.75		5.8	50	1754.175
10	Plastic wall insert, plastic drilled hole dia. 14 mm	70 mm		0.3	25	4008.072
		100 mm		0.3	25	4008.102
		135 mm		0.3	25	4008.137
11	Ring screw, steel, galvanized, dia. 12 mm, for expanding plug	95 mm		1.6	10	4009.097
		120 mm		1.8	10	4009.122
		190 mm		2.5	10	4009.192
		230 mm		3.0	10	4009.232
		300 mm		3.5	10	4009.302
		350 mm		5.0	10	4009.352
12	Scaffolding lock basic set, 20 locks, 2 keys and code card basic set, 20 locks, 2 keys and code card basic set, 50 locks, 4 keys and code card Expansion set with same locking as basic set Expansion set with same locking as basic set			2.2	10	4000.003
				4.2	20	4000.004
				10.5	50	4000.005
				4.2	20	4000.006
				10.5	50	4000.007

WS = wrench size PU = packaging unit = available ex works = delivery time on request = only available in this packaging unit = the approval process is not yet completed

IND = Layher Individual possible – see page 7

Brackets

Widening of scaffolding can be easily performed by fitting **brackets** in the rosette on the standard. System decks in brackets must be secured against lifting off with the **lift-off preventer** (page 19).

Widened scaffolding can also be constructed with O-ledgers or U-transverse ledgers, base collar and diagonal braces in any projection depending on the working load. Structural strength verification is required here for each individual case.

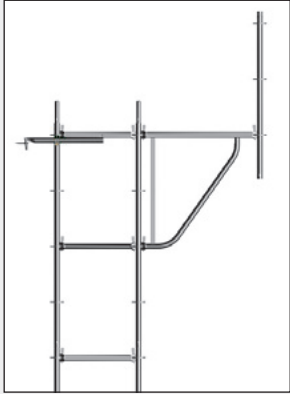

The **bracket, 1.09 m wide 6** is used for widening birdcage scaffolding. Transverse ledger at the height of the lower bracket connection is required. Permissible load capacity: 2.0 kN/m² for bay widths 3.07 m.

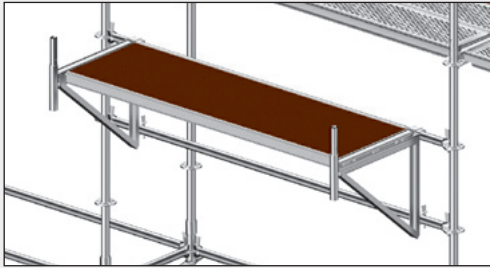

U-bracket, with 2 hooks 7/8, suspended from the ledgers, for projecting platforms.

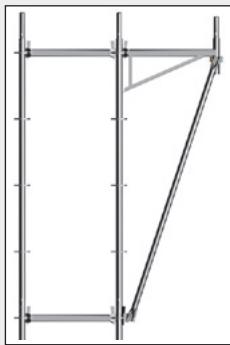

The **bracket brace 2.05 m 9** is used to support the 0.73 m bracket.

The **O-bracket, 0.69 m wide, adjustable 13** is used incrementally and facilitates optimum stand height and wall distance.

Original Allround Scaffolding from Layher is made up of more than just standards and ledgers: complete system technology with additional parts and accessories to suit the construction site provides for safety and assembly benefits at all sites. System brackets are available for quickly widening scaffolding bays and for converting projecting building parts and eaves.

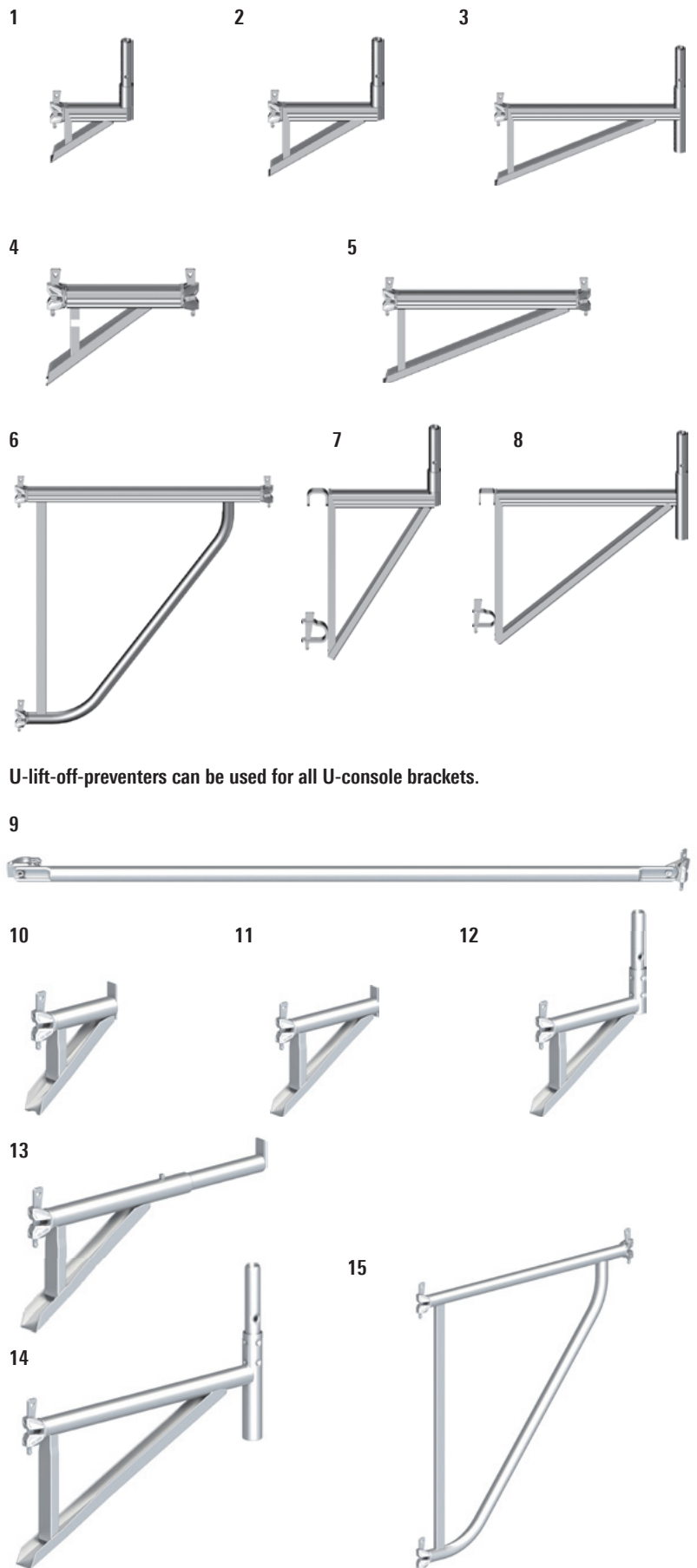

U-lift-off-preventers can be used for all U-console brackets.

Pos.	Description	Dimensions L/H x W [m]	Weight approx. [kg]	PU [pcs.]	Ref. No.
1	U-console bracket LW , 0.28 m wide for U-deck 0.19 m wide, lift-off preventer provided by customer	0.28	3.4	100	2632.019
2	U-console bracket LW , 0.39 m wide for U-deck 0.32 m wide	0.39	3.9	125	2632.039
3	U-console bracket LW , 0.73 m wide for 2 U-decks 0.32 m or 1 U-deck 0.61 m wide	0.73	6.4	80	2632.073
4	U-console bracket LW , 0.45 m wide, with 2 wedge heads for U-decks, 0.32 m wide	0.45	3.1	80	2632.045
5	U-console bracket LW , 0.73 m wide, with 2 wedge heads for U-decks, 2 x 0.32 m wide or 1 x 0.61 m	0.73	5.0	80	2632.074
6	U-console bracket LW , 1.09 m wide with U-section, for 3 U-decks 0.32 m wide	1.09	12.0	30	2632.109
7	U-console bracket , with 2 hooks, 0.36 m wide for U-decks, 0.32 m wide	0.36	6.6	80	4005.036
8	U-console bracket , with 2 hooks, 0.73 m wide for U-decks, 2 x 0.32 m or 1 x 0.61 m wide	0.73	8.5	40	4005.073
9	Bracket brace , 2.05 m	2.05	8.8	50	2631.205
10	O-console bracket , 0.26 m wide, without spigot for O-deck 0.19 m wide	0.26	2.3	250	2631.026
11	O-console bracket , 0.36 m wide, without spigot for O-deck 0.32 m wide	0.36	3.4	125	2630.038
12	O-console bracket , 0.39 m wide for O-deck 0.32 m wide	0.39	3.9	125	2631.039
13	O-console bracket , 0.69 m wide, adjustable pushed in: for accommodating 2 x 0.19 m O-steel decks T4 pulled out: for accommodating 3 x 0.19 m O-steel decks T4	0.69	4.2	125	2630.069
14	O-console bracket , 0.73 m wide for 2 O-decks 0.32 m or 1 O-deck 0.61 m wide	0.73	6.8	80	2631.073
15	O-console bracket , 1.09 m wide for 3 O-decks 0.32 m wide	1.09	12.0	30	2631.109



Assembly situation: **U-console bracket, 0.73 m wide 3** (top) or alternatively **U-ledger 0.73 m** in conjunction with **bracket brace 2.05 m 9** (left).



U-ledgers with gap cover, 0.11 m wide are available in a variety of lengths for gap-free work surfaces between U-main scaffolding decks and U-console bracket decks (see pages 42 / 43).

WS = wrench size PU = packaging unit = available ex works = delivery time on request = only available in this packaging unit = the approval process is not yet completed

IND = Layer Individual possible – see page 7

Pedestrian protection, brick guard, scaffolding enclosure

The **U-walkway beam LW 1** is designed for further construction with 0.73 m or 1.09 m wide scaffolding. Additional bracing is required for constructing pedestrian passages.

The heightened side protection specified for roofing work is swiftly assembled in Allround Scaffolding: The **side protection nets** are attached at the top, at scaffolding deck height, to the O-ledge. Without a quick strap fastener, the protection net is threaded with each loop of its mesh into the O-ledgers. With quick strap fasteners, the side protection net is attached to the O-ledgers at every 750 mm. Toe board and handrail are required.

Side protection net 10.00 x 2.00 m,
Specification: Mesh width 100 mm, blue, made of PPM 4.5 mm, knotless, as per DIN EN 1263-1.

Scaffolding tarpaulins and nets

To protect passers-by and traffic during spraying work and other site work causing dirt, facade scaffolding is covered with tarpaulins and nets.

Layher scaffolding tarpaulins and nets meet the requirements of DIN 4420-1. Compliance with design parameters prevents objects falling from the scaffolding level.

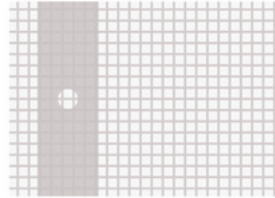
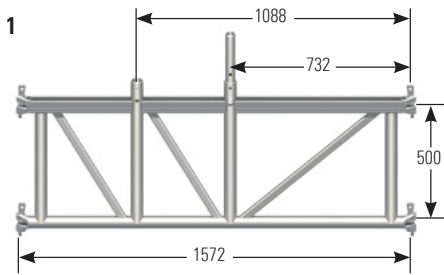

Scaffolding tarpaulin

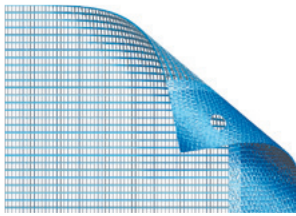

Scaffolding net

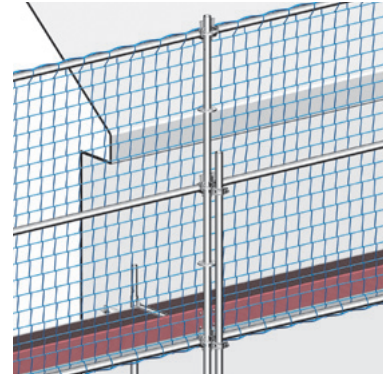

Brick guard

 Scaffolding tarpaulins and nets you'll find in the catalogue System-free Accessories.



Brick guard 2

The nets are attached at the bottom (at scaffolding deck height) and at the top (2 m above the scaffolding deck) to the tubes at every 750 mm. Toe board and handrail are required.

Side protection net 10.00 x 2.00 m, Specification: Mesh width 100 mm, blue, made of PPM 4.5 mm, knotless, as per DIN EN 1263-1.

2

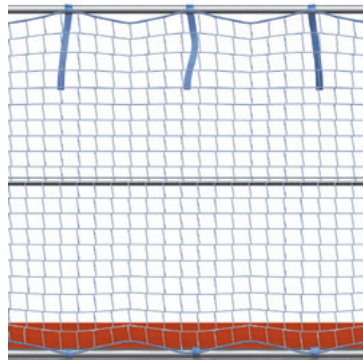

3

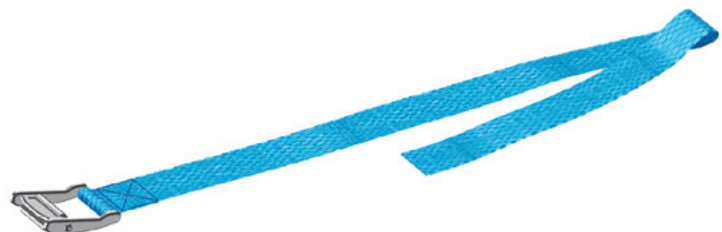

Pos.	Description	Dimensions L/H x W [m]	Weight approx. [kg]	PU [pcs.]	Ref. No.
1	U-walkway beam LW , 1.57 m wide Steel up to load class 4 up to bay length 3.07 m and load class 4: max. assembly height 14 m	1.57 x 0.50	20.9	25	2666.157 



U-walkway beam

2	Protection net with quick strap fastener	10.00 x 2.00	5.9	40	6232.002
3	Quick strap fastener	0.50	1.5	50 	6235.002

WS = wrench size PU = packaging unit  = available ex works  = delivery time on request  = only available in this packaging unit  = the approval process is not yet completed

IND = Layher Individual possible – see page 7

Platform stairway, comfort stairway



Safe, fatigue-free stairway ascent – also with transportation of materials – without impairment of the working surface. With the **platform stairway 1**, it is simple to construct a 4-standard stairtower, either integrated into the scaffolding or as a free-standing access structure anchored on the building. Both parallel and opposite stairways are possible here. There is no hindrance to work on scaffolding with this version. Permissible load capacity: 2.0 or 2.5 kN/m²

The **comfort stairway 2** bases on the platform stairway. It is equipped with 175 mm wide, grooved steps. That leads to more comfortable access – especially for high access heights. The stronger stringer profile offers only small bending guardrails, internal guardrails and stairwell guardrails can be used from the platform stairway.

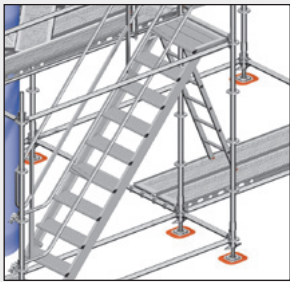

The **internal stairway guardrail 5** is required for opposite stairways and serves to increase the stability of single-flight stairways.

The **stairway guardrail post 7** with the **O-ledge with wedge head and U-fork 8** is used for the stairwell at the top level. Optionally the exit of the top stair level can be assembled with console brackets. In that case, the stairwell guardrail is not needed.

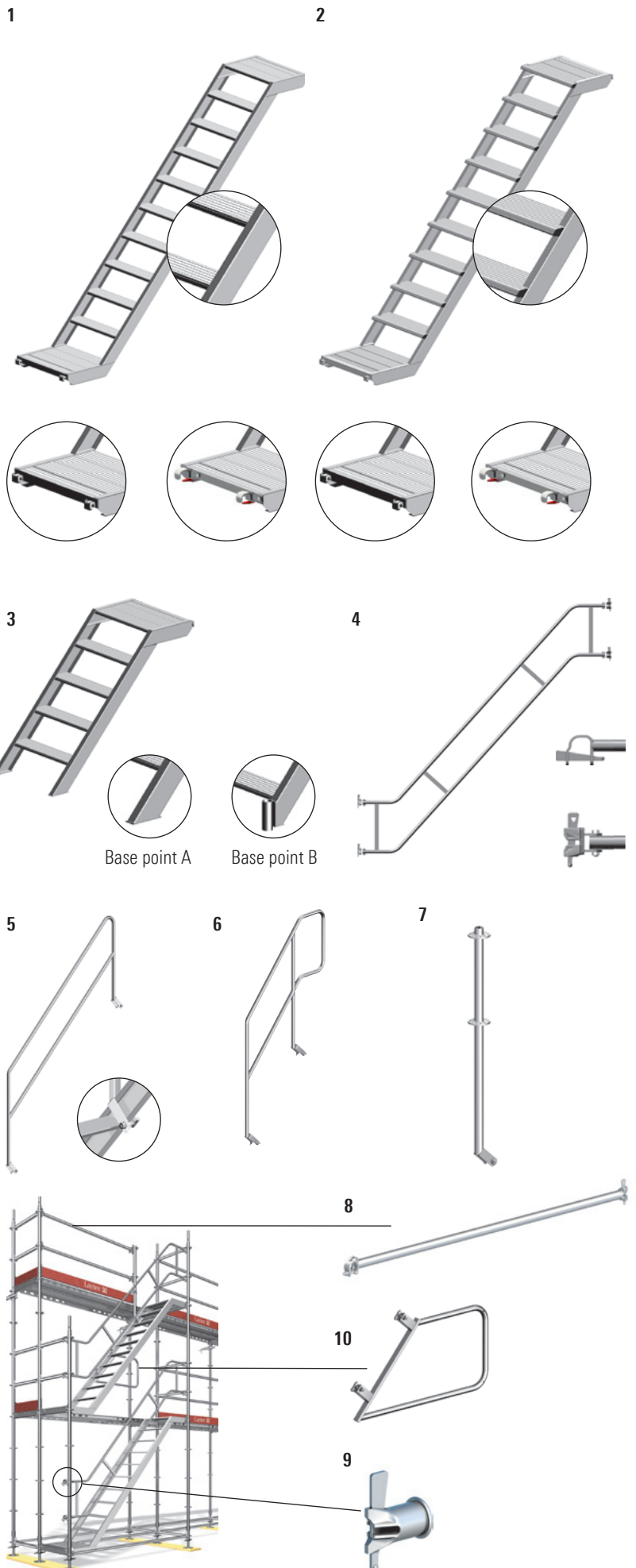
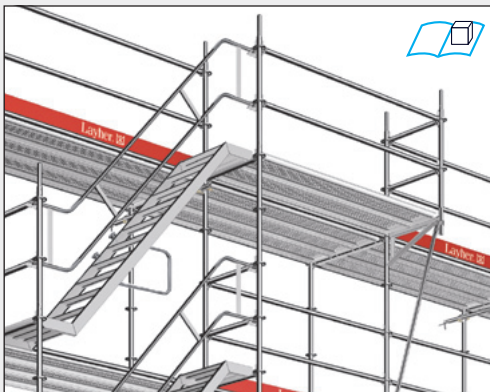

Pos.	Description	Dimensions L / H x W [m]	Weight approx. [kg]	PU [pcs.]	Ref. No.
1	Platform stairway , aluminium, stair class A acc. to EN 12811-1 U-version, 0.64 m wide, 2.5 kN/m ² , 2.00 m high, for 2.57 m bay length; step height 0.20 m U-version, 0.64 m wide, 2.5 kN/m ² , 2.00 m high, for 3.07 m bay length; step height 0.20 m U-version, 0.64 m wide, 2.5 kN/m ² , 1.50 m high, for 2.57 m bay length; step height 0.18 m U-version, 0.94 m wide, 2.0 kN/m ² , 2.00 m high, for 2.57 m bay length; step height 0.20 m U-version, 0.94 m wide, 2.0 kN/m ² , 2.00 m high, for 3.07 m bay length; step height 0.20 m U-version, 0.94 m wide, 2.0 kN/m ² , 1.50 m high, for 2.57 m bay length; step height 0.18 m O-version, 0.64 m wide, 2.5 kN/m ² , 2.00 m high, for 2.57 m bay length; step height 0.20 m O-version, 0.64 m wide, 2.5 kN/m ² , 2.00 m high, for 3.07 m bay length; step height 0.20 m O-version, 0.64 m wide, 2.5 kN/m ² , 1.50 m high, for 2.57 m bay length; step height 0.18 m	2.57 x 0.64	21.9	10	1753.257
		3.07 x 0.64	26.3	10	1753.307
		2.57 x 0.64	21.5	10	1753.251
		2.57 x 0.94	33.7	10	1753.258
		3.07 x 0.94	40.1	10	1753.308
		2.57 x 0.94	36.6	10	1753.252
		2.57 x 0.64	23.2	10	2633.257
		3.07 x 0.64	27.7	10	2633.307
		2.57 x 0.64	22.8	10	2633.258
		2	Comfort stairway , aluminium, stair class B acc. to EN 12811-1 U-version, 0.64 m wide, 2.5 kN/m ² , 2.00 m high, for 2.57 m bay length; step height 0.22 m U-version, 0.64 m wide, 2.5 kN/m ² , 2.00 m high, for 3.07 m bay length; step height 0.22 m U-version, 0.94 m wide, 2.5 kN/m ² , 2.00 m high, for 2.57 m bay length; step height 0.22 m O-version, 0.64 m wide, 2.5 kN/m ² , 2.00 m high, for 2.57 m bay length, step height 0.22 m O-version, 0.94 m wide, 2.0 kN/m ² , 2.00 m high, for 2.57 m bay length, step height 0.22 m	2.57 x 0.64	27.0
3.07 x 0.64	32.0			10	1755.307
2.57 x 0.94	37.0			10	1755.258
2.57 x 0.64	29.2			10	2635.257
2.57 x 0.94	39.1			10	2635.258
3	Starting stairway , aluminium, stair class A acc. to EN 12811-1 U-Version, 0.64 m wide, 2.5 kN/m ² , 1.00 m high, step height 0.20 m, base point A U-Version, 0.64 m wide, 2.5 kN/m ² , 1.20 m high, step height 0.20 m, base point B U-Version, 0.64 m wide, 2.5 kN/m ² , 1.70 m high, step height 0.19 m, base point B U-Version, 0.94 m wide, 2.0 kN/m ² , 1.00 m high, step height 0.20 m, base point A U-Version, 0.94 m wide, 2.0 kN/m ² , 1.00 m high, step height 0.20 m, base point B O-Version, 0.64 m wide, 2.5 kN/m ² , 1.00 m high, step height 0.20 m, base point A O-Version, 0.64 m wide, 2.5 kN/m ² , 1.20 m high, step height 0.20 m, base point B			1.00 x 0.64	11.5
		1.20 x 0.64	13.5	10	1753.002
		1.70 x 0.64	18.3	10	1753.004
		1.00 x 0.94	16.8	10	1753.005
		1.20 x 0.94	17.0	10	1753.001
		1.00 x 0.64	13.8	10	2633.003
		1.20 x 0.64	15.3	10	2633.002
		4	Stairway guardrail , steel galvanized, for Pos. 1, 2 2.00 m high, for 2.57 m bay length with U-fork 2.00 m high, for 3.07 m bay length with U-fork 2.00 m high, for 2.57 m bay length with swivelling wedge head 2.00 m high, for 3.07 m bay length with swivelling wedge head 1.50 m high, for 2.57 m bay length with U-fork 1.50 m high, for 2.57 m bay length with swivelling wedge head	2.57	18.1
3.07	20.1			30	2638.307
2.57	18.1			30	2638.258
3.07	20.1			30	2638.308
2.57	17.0			30	2638.251
2.57	17.0			30	2638.252
5	Internal stairway guardrail T12 , steel galvanized, mandatory for opposite-direction stairways 2.00 m high 2.00 m high 1.50 m high 1.00 m high			2.25	13.5
		2.25	13.5	20	1752.008
		2.00	11.5	20	1752.012
		0.90	7.8	20	1752.011
		6	Initial stairway guardrail	0.90 x 1.70	9.9
0.90 x 1.70	9.9			20	1752.013
7	Stair guardrail post is used for the stairwell at the top level	1.30	6.1	28	2638.400
8	O-ledger with wedge head and U-fork , is used for the stairwell at the top level for 2.57 m bay length for 3.07 m bay length	1.90	7.8	50	2638.401
		2.15	9.7	50	2638.402
		9	Stairway guardrail adapter		0.7
10	Stairwell guardrail				6.2
			6.2	40	1752.014

WS = wrench size PU = packaging unit = available ex works = delivery time on request = only available in this packaging unit = the approval process is not yet completed

= Layher Individual possible – see page 7

Modular stairway, outside access, construction staitower 200

With the **modular stairway**, accesses that always fit and that match the system can be constructed. Any intermediate dimension can be achieved simply by fitting together the individual stairway parts. The stairway rises 20 cm from step to step, and the bottom element with spindles is used for precise levelling. A wide variety of applications thanks to modular design. Little space needed for transport and assembly.

Height differences from 0.60 m to 1.60 m can be bridged. Load-bearing capacity: 3.0 kN/m². Design: steel, hot-dip galvanized. Connection of elements with **bolt dia. 12 x 55 mm** and **safety clip dia. 2.8 mm** (2 per joint). (They are already included in the scope of delivery).

Constructing outward-facing access bays requires simple **scaffolding ladders** together with the **swing door** and the **guardrail standard, 1.70 m, bended**.



Layher pole ladders for scaffolding conform to DIN EN 131 individually or when connected to each other. The stile connections must have proper support and be secured with spring clips.

The regulations in DGUV 38 must be followed.

Stairtowers can be used in many areas outside scaffolding construction, e.g. in public areas and as escape stairtowers.

The **U-/O-stairway stringer 200, 10-step 9** and the **platform stairway, aluminium** (see page 38) are not just a quick and comfortable means of upward access which permits problem-free vertical transportation of materials and working on all scaffolding levels, they also easily enable stairtowers of differing widths and load capacities to be built for the purpose of rapidly linking up various construction site levels.

U-/O-stairway stringer 200		
	10 steps	Permissible load with a stair flight width of 1.29 m
Riser s	20.0 cm	
Tread a	24.1 cm	
Undercut u	7.9 cm	2.0 kN/m ²



Installation situation of Allround O-side part 0.75 m

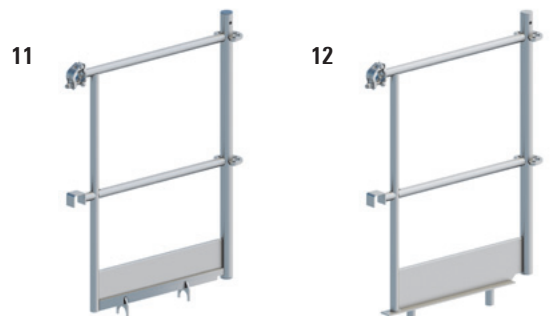
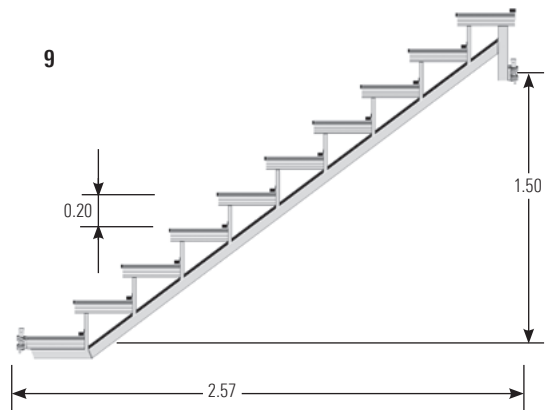
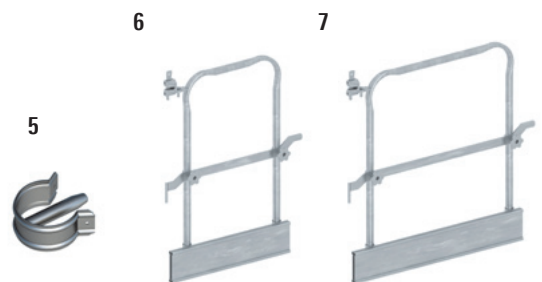
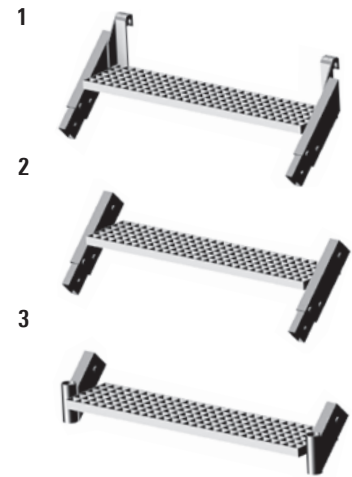
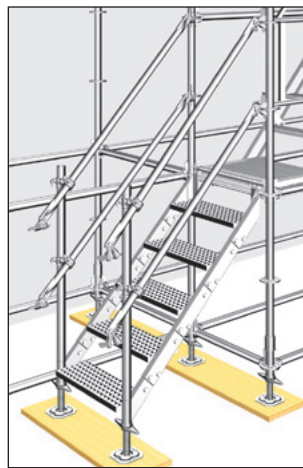

Locks the deck, which bears in the stringers against lift-off.

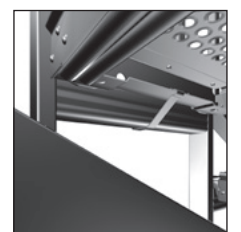

Pos.	Description	Dimensions L/H x W [m]	Weight approx. [kg]	PU [pcs.]	Ref. No.	
1	U-stair head section , 0.60 m U-stair head section , 0.95 m Spigot preassembled with bolts and safety clips	0.60	10.7	15	2637.060	
		0.95	11.7	50	2637.095 🇩🇪	
2	Stair middle section , 0.60 m Stair middle section , 0.95 m Spigot preassembled with bolts and safety clips	0.60	9.2	15	2638.060	
		0.95	10.2	50	2638.095 🇩🇪	
3	Stair foot section , 0.60 m Stair foot section , 0.95 m	0.60	6.8	15	2639.060	
		0.95	7.8	50	2639.095 🇩🇪	
4	Pole ladder , aluminium	10 rungs	2.90 x 0.46	8.2	50	1004.010
		14 rungs	4.00 x 0.46	11.3	50	1004.014
		17 rungs	4.90 x 0.46	13.8	50	1004.017
		20 rungs	5.70 x 0.46	16.1	50	1004.020
	Pole ladder , steel	6 rungs	1.50 x 0.43	12.0	50	1002.006 🇩🇪
		8 rungs	2.00 x 0.43	15.0	50	1002.008 🇩🇪
		12 rungs	3.00 x 0.43	21.5	50	1002.012 🇩🇪
		16 rungs	4.00 x 0.43	28.0	50	1002.016 🇩🇪
5	Spring clip , 11 mm pin for securing the joint connections of the extended pole steel / aluminium scaffolding ladder Ref. No. 1002 / 1004		0.1	200	1250.000	
6	Swing door , 0.73 m, adjustable	0.73	7.8	40	2627.073 🇩🇪	
7	Swing door , 1.00 m, adjustable	1.00	9.2	40	2627.100 🇩🇪	
8	Guardrail standard , 1.70 m, bended	1.70	8.5	50	2606.170 🇩🇪	
9	U-stairway stringer 200 , 10-step, 2.00 m storey height	2.00 x 2.57	28.4	20	2639.010 🇩🇪	
	O-stairway stringer 200 LW , 10-step, 2.00 m storey height	2.00 x 2.57	28.4	20	2638.011 🇩🇪	
10	Lift-off prevention clamp		1.0	20	2634.032 🇩🇪	
11	O-side part , 0.75 m	WS 0.75 x 1.00	11.9	30	2627.015 🇩🇪	
		WS 0.75 x 1.00	11.9	25	2627.017 🇩🇪	
12	U-side part , 0.75 m	WS 0.75 x 1.00	11.2	30	2627.016 🇩🇪	
		WS 0.75 x 1.00	11.2	25	2627.018 🇩🇪	

In the 12-standard construction stairtower 200, the stairways are made up of individual **U-/O-stairway stringers 200, 10-step** and steps made of standard decks. Thus the weights / volumes of the individual parts are lower, the proportions of standard material higher, and the additional costs lower. In addition, different variants of stairway widths are possible.



WS = wrench size PU = packaging unit 🇩🇪 = available ex works 🇩🇪 = delivery time on request 🇩🇪 = only available in this packaging unit 🇩🇪 = the approval process is not yet completed

IND = Layer Individual possible – see page 7

Stairtowers 500 and 750

Separate stringers and standard decking ensure variable widths for the stairway (1.09 m, 1.57 m, 2.07 m). This keeps the weight and the volume of the components low and permits a high proportion of standard Layher Allround material to be used.

The 16-standard ground plan of the stairtowers 500 and 750 allows both temporary and stationary stairtower structures of high loading capacity to be built.



The stairtower 500 is used for preference in non-public areas, e.g. as access to the construction site, as non-public road crossings during construction work or as additional escape stairtower. In special cases it also can be used in public areas.

U-/O-stairway stringer 500				
	9 steps	5 steps (U-version)	Permissible load with a stair flight width of 2.07 m	
Riser s	20.0 cm	20.0 cm		5.0 kN/m ²
Tread a	27.5 cm	29.0 cm		
Under-cut u	4.5 cm	3.0 cm		



The stairtower 750 with child protected guardrail is thanks to its riser measures mainly used in public areas and event constructions as access to stages and grandstands. Its features are the high load-bearing capacity and the reduced stairway riser.

U-stairway stringer 750					
	8 steps	5 steps	2 steps	Permissible load with a stair flight width of 2.07 m	
Riser s	16.6 cm	16.7 cm	16.7 cm		7.5 kN/m ²
Tread a	31.0 cm	29.0 cm	32.7 cm		
Under-cut u	1.0 cm	3.0 cm	-0.7 cm		

A height adjustment outside the 2.00 m or 1.50 m standard dimension is achieved with 5-step stairway stringers (1.00 m high). Alternatively, the stairway stringers 500 and 750 can also be combined in the stairtower structure.

The stairtower structures must be verified for each single structure as regards structural strength.

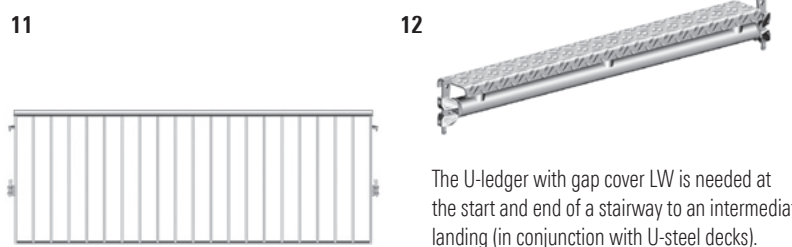
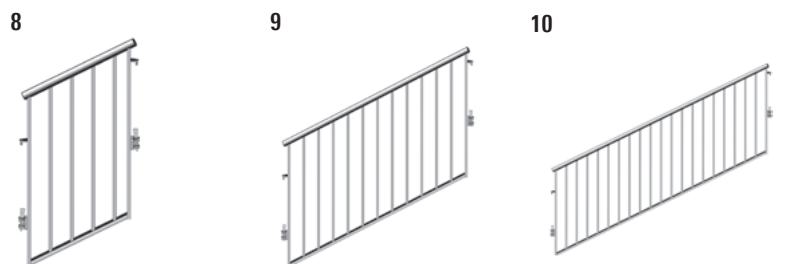
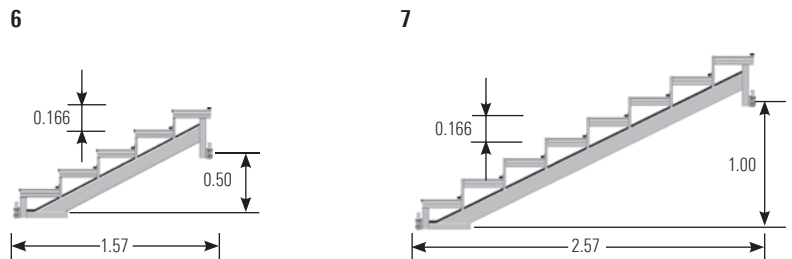
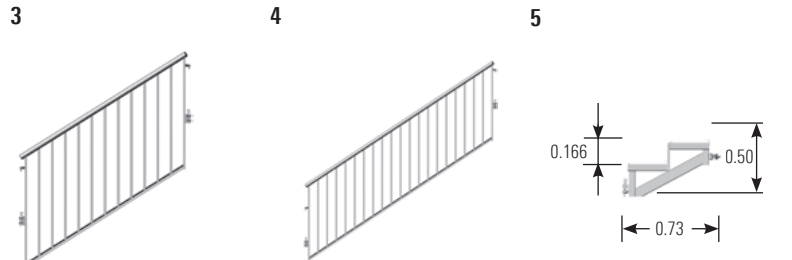
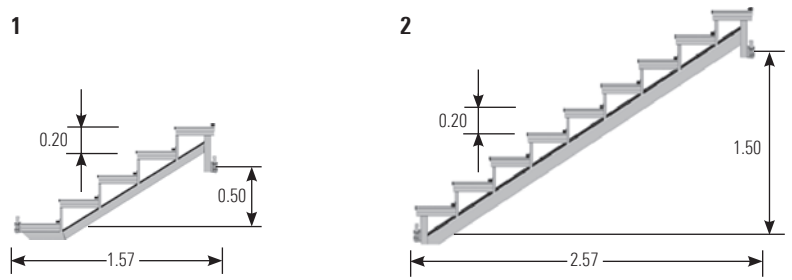

The U-ledge with gap cover LW is needed at the start and end of a stairway to an intermediate landing (in conjunction with U-steel decks).

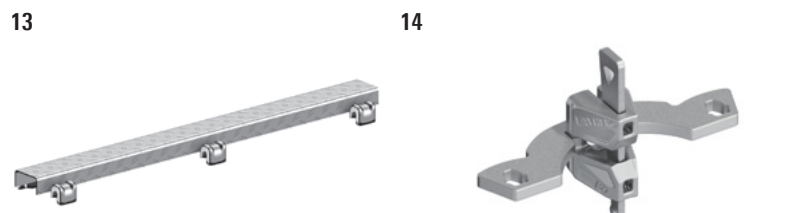

Pos.	Description	Dimensions L/H x W [m]	Weight approx. [kg]	PU [pcs.]	Ref. No.	
1	U-stairway stringer 500 LW, 5 steps (1.00 m storey height)	1.00 x 1.57	18.0	20	2639.004	
2	U-stairway stringer 500 LW, 9 steps (2.00 m storey height)	2.00 x 2.57	34.0	20	2639.009	
	O-stairway stringer 500 LW, 9 steps (2.00 m storey height)	2.00 x 2.57	36.0	20	2638.012	
3	Guardrail for stairs 500 T12, 5 steps (1.00 m storey height)	1.00 x 1.57	24.8	25	2616.104	
4	Guardrail for stairs 500 T12, 9 steps (2.00 m storey height)	2.00 x 2.57	35.8	25	2616.100	
5	U-stairway stringer 750 LW, 2 steps (0.50 m storey height)	0.50 x 0.73	8.9	20	2639.002	
	O-stairway stringer 750 LW, 2 steps (0.50 m storey height)	0.50 x 0.73	10.8	20	2638.013	
6	U-stairway stringer 750 LW, 5 steps (1.00 m storey height)	1.00 x 1.57	19.2	20	2639.005	
	O-stairway stringer 750 LW, 5 steps (1.00 m storey height)	1.00 x 1.57	19.9	20	2638.014	
7	U-stairway stringer 750 LW, 8 steps (1.50 m storey height)	1.50 x 2.57	36.4	20	2639.008	
	O-stairway stringer 750 LW, 8 steps (1.50 m storey height)	1.50 x 2.57	37.2	20	2638.015	
8	Guardrail for stairs 750 T12, 2 steps (0.50 m storey height)	0.50 x 0.73	14.8	25	2616.110	
9	Guardrail for stairs 750 T12, 5 steps (1.00 m storey height)	1.00 x 1.57	24.3	25	2616.105	
10	Guardrail for stairs 750 T12, 8 steps (1.50 m storey height)	1.50 x 2.57	34.6	25	2616.101	
11	Guardrail T12 with child protection	0.45	10.4	25	2616.045	
		0.73	14.1	25	2616.073	
		1.09	17.8	25	2616.109	
		1.29	19.4	25	2616.129	
		1.40	20.6	25	2616.140	
		1.57	22.7	25	2616.157	
		2.07	27.7	25	2616.207	
		2.57	32.7	25	2616.257	
12	U-ledger with gap cover LW, 0.11 m width	0.73	5.2	200	2675.073	
		1.09	7.6	50	2675.109	
		1.29	8.9	50	2675.129	
		1.40	9.7	50	2675.140	
		1.57	10.8	50	2675.157	
		2.07	14.2	50	2675.207	
		2.57	17.6	50	2675.257	
		O-ledger with gap cover LW, 0.11 m width	0.73	5.2	50	2675.074
	1.09		7.5	50	2675.110	
	1.29		9.0	50	2675.130	
	1.40		9.4	50	2675.141	
	1.57		11.0	50	2675.158	
	2.07		14.1	50	2675.208	
	2.57		18.1	50	2675.258	
	13		U-gap cover with claws	1.09	5.0	50
		1.29		6.0	50	3868.129
1.40		6.5		60	3868.140	
1.57		7.3		50	3868.157	
2.07		9.7		50	3868.207	
14	Guardrail fixing device		0.8	25	2636.000	



WS = wrench size PU = packaging unit = available ex works = delivery time on request = only available in this packaging unit = the approval process is not yet completed

IND = Layer Individual possible – see page 7

System handrail

Stairtowers, wheelchair ramps or bridges open to the public must, to conform to German state building regulations, be provided with continuous handrails. With the system handrail, complex one-off designs and assembly work can be avoided. With just three parts – handrail holder, joint and handrail tube – the guardrail can be installed quickly and easily in line with regulations for every stair type. The lightweight aluminium handrail tubes of dia. 42.3 mm for a comfortable grip are easy to cut and drill holes into, and also quick to clean. They are simply riveted to the fitted handrail holders.

With rotating joints that permit any angle between 90° and 180° to be set and used, all transitions between the handrail tubes are smooth and pleasant to the touch.

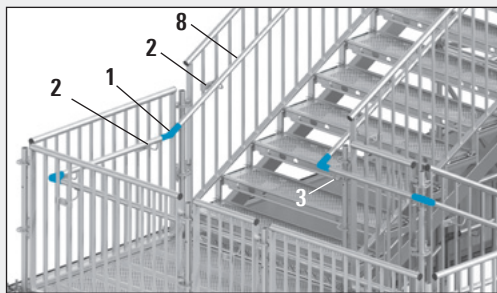

For information about the assembly, see the **instructions for assembly and use for the system handrail**.

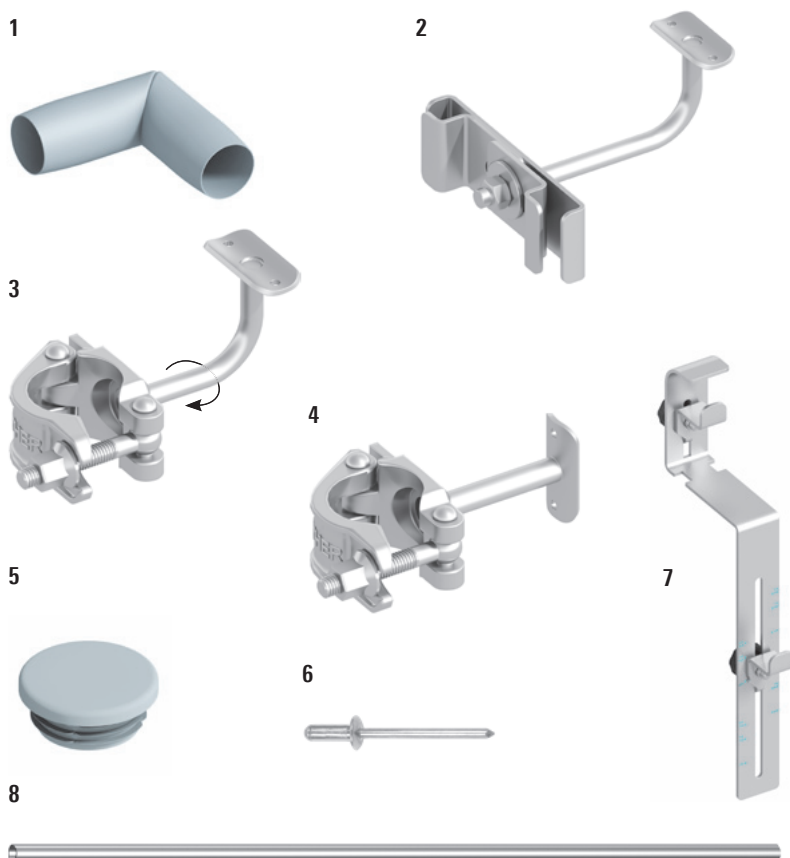

Step cover

Sure footing with **Layher step covers**. With their non-slip surface using quartz sand, they ensure maximum safety on Layher stairways in rain, snow and ice conditions. The step covers are made from glass-fibre-reinforced plastic. They are permanently resistant to weather effects, easy to clean, electrically non-conductive and flame-retardant. They can be fitted quickly and are optimally matched to the Layher stairway range.

A dependable solution for safe footing in all weather conditions.

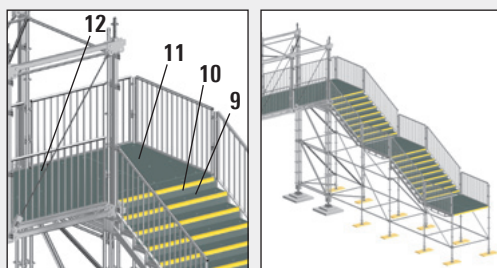

The risers and the step covers correspond to the non-slip value R13 according to DIN EN 51130.

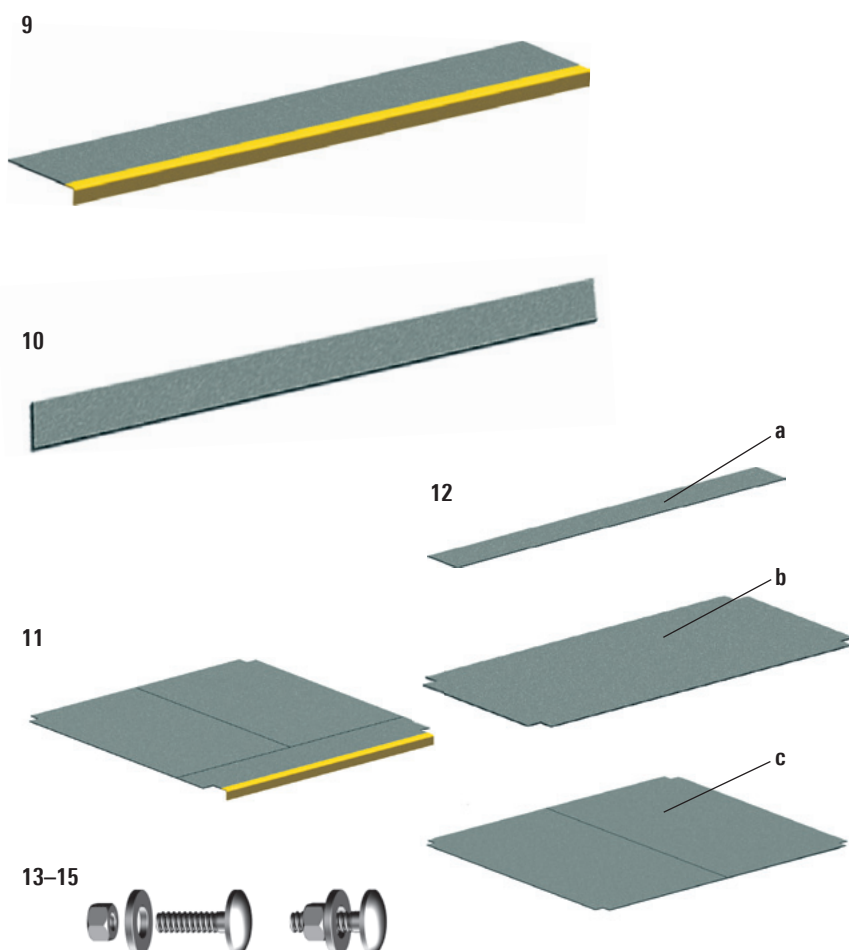

Pos.	Description	Dimensions L / H x W [m]	Weight approx. [kg]	PU [pcs.]	Ref. No.
1	Joint for system handrail, 10 pcs. Infinitely adjustable from 90 to 180°		1.0	10	2616.007
2	System handrail holder for child safety guardrail		0.7	10	2616.001
3	System handrail holder with half-coupler		1.0	10	2616.008
4	System handrail holder with half-coupler, vertical		0.9	10	2616.004
5	End caps for system handrail tube, plastic, 10 pcs.		0.1	10	2616.009
6	Blind rivet 4.8 x 12, 100 pcs. for fastening the handrail tubes to the handrail holder		0.5	100	6493.357
7	Assembly aid for system handrail		1.2	10	2616.005
8	System handrail tube, aluminium, dia. 42.3 mm, 6.00 m		4.3	10	2616.003

Pos.	Description	Dimensions L / H x W [m]	Weight approx. [kg]	PU [pcs.]	Ref. No.
9	Step cover Necessary fixation material: each 3 pcs. (of PU 50 pcs.) Pos. 13–15	1.57 x 0.33	3.2	20	4000.157
		2.07 x 0.33	4.2	20	4000.207
10	Riser Necessary fixation material: each 2 pcs. (of PU 50 pcs.) Pos. 13–15	1.57 x 0.16	1.6	20	4001.157
		2.07 x 0.16	2.0	20	4001.207
11	Landing cover with nose for adjacent stair Necessary fixation material: each 21 pcs. (of PU 50 pcs.) Pos. 13–15	1.57 x 1.57	15.3	20	4002.157
		2.07 x 2.07	26.6	20	4002.207
12	Landing cover a) flat, for use in intermediate bay Necessary fixation material: each 2 pcs. (of PU 50 pcs.) Pos. 13–15	1.57 x 0.15	1.5	20	4003.015
		2.07 x 0.15	2.0	20	4003.016
	b) flat, for use in intermediate bay Necessary fixation material: each 6 pcs. (of PU 50 pcs.) Pos. 13–15	1.57 x 0.73	7.1	20	4003.073
		2.07 x 0.73	9.4	20	4003.074
	c) flat, for use on platforms Necessary fixation material: each 18 pcs. (of PU 50 pcs.) Pos. 13–15	1.57 x 1.57	15.3	20	4003.157
		2.07 x 2.07	26.6	20	4003.207
13	Countersunk bolt M8 x 30		0.6	50	6495.069
14	Securing nut M8		0.2	50	6494.580
15	Spring washer A 8.4 x 18 mm		0.3	50	6495.070

WS = wrench size PU = packaging unit = available ex works = delivery time on request = only available in this packaging unit = the approval process is not yet completed

IND = Layer Individual possible – see page 7

Stringers and guardrails for modular stairway

Modular stairway at scaffolding

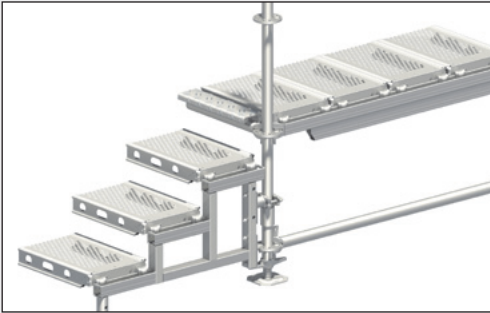

Modular stairway at Event stage

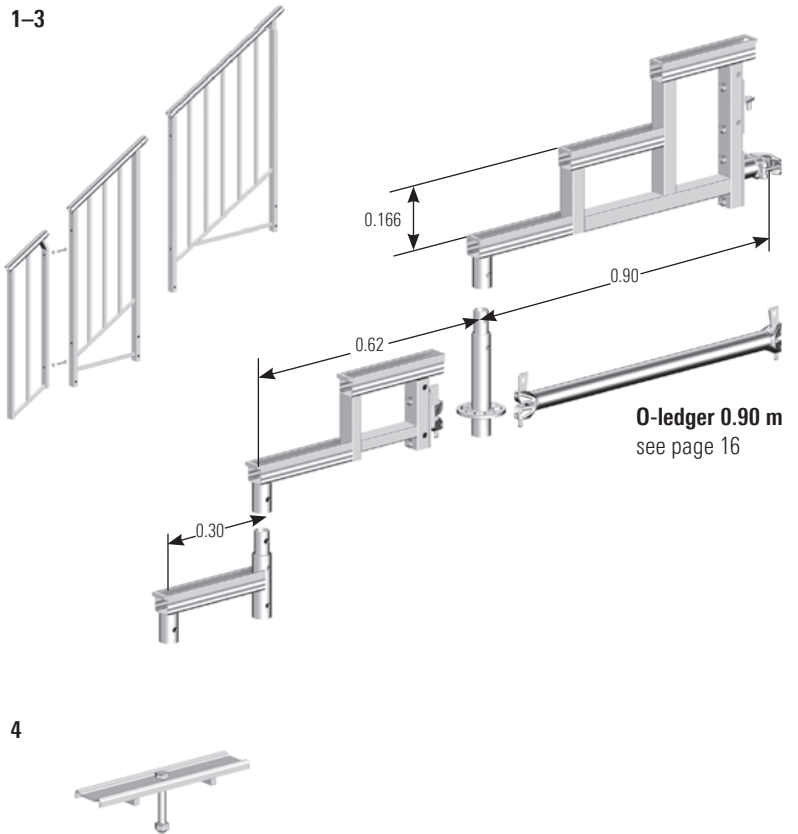
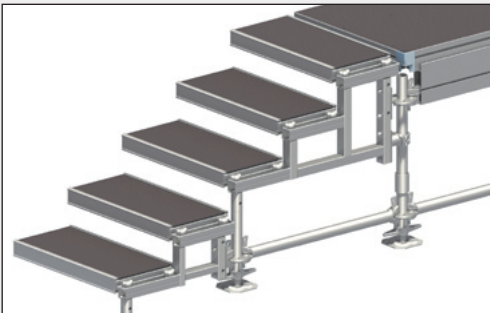

Lattice beams

The **U-lattice beam, steel 5** and the **U-lattice beam, aluminium 5**, with 4 wedge heads for locating on standards are used to construct birdcage scaffolding or in conjunction with the **spigot for U-lattice beam 9**, for further construction in the scaffolding standard dimension or for bridging.

O-lattice beam, with 4 wedge heads 6, steel, is used for further construction in the scaffolding standard dimension. The top and bottom cylindrical tube chords are secured to the standard with the wedge heads.

U-ledger for lattice beam 7 for accommodating scaffolding decks for bridging with Allround lattice beams.

Applicable to lattice beams: when lattice beams are used, the stability of the scaffolding must be verified in each case. Loading tables available on request. The scaffolding deck must be secured against lifting off in each case with **U-lift-off preventer**.

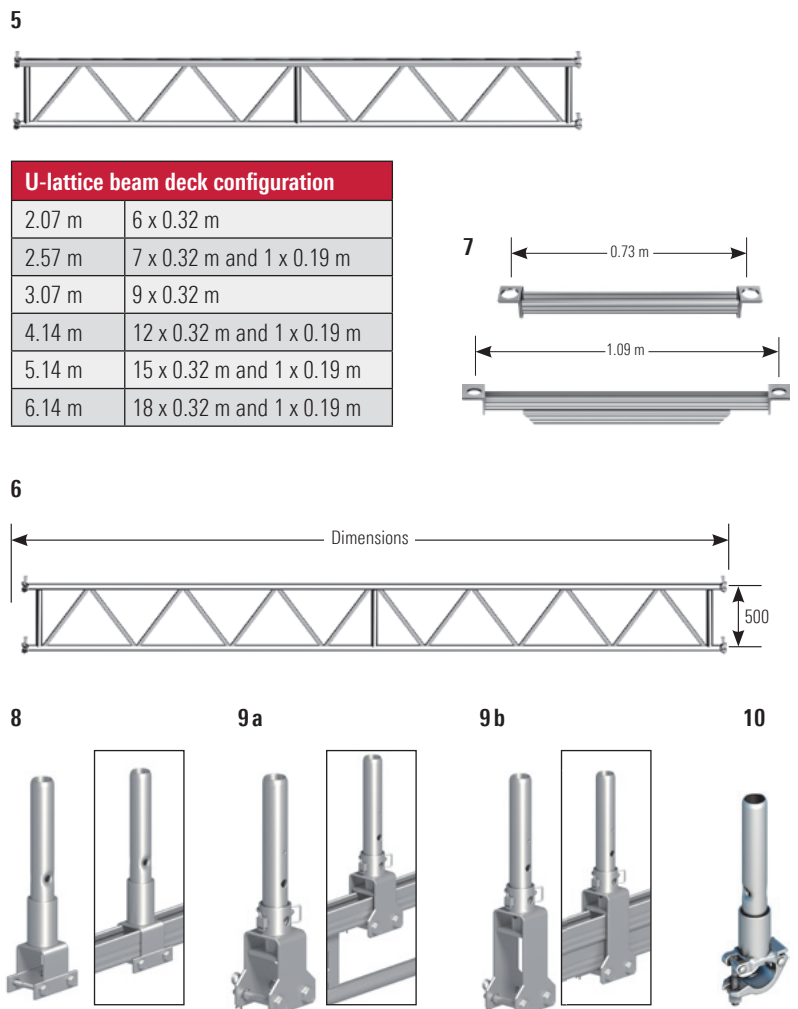

U-lattice beam deck configuration	
2.07 m	6 x 0.32 m
2.57 m	7 x 0.32 m and 1 x 0.19 m
3.07 m	9 x 0.32 m
4.14 m	12 x 0.32 m and 1 x 0.19 m
5.14 m	15 x 0.32 m and 1 x 0.19 m
6.14 m	18 x 0.32 m and 1 x 0.19 m

Pos.	Description		Dimensions L / H x W [m]	Weight approx. [kg]	PU [pcs.]	Ref. No.
1	Stringer for modular stairway	1-step		2.4	50	5407.001
		2-step		5.5	50	5407.002
		3-step		8.0	20	5407.003
2	Base collar 0.26 m, for modular stairway with spigot			2.0	450	5407.021
3	Guardrail for modular stairway	1-step		6.5	40	5407.011
		2-step		14.0	25	5407.012
		3-step		16.0	25	5407.013
4	Lift-off preventer with bolt		0.29	0.4	500	5407.030

Pos.	Description		Dimensions L / H x W [m]	Weight approx. [kg]	PU [pcs.]	Ref. No.
5	U-lattice beams LW, with 4 wedge heads, steel		2.07 x 0.50	21.4	40	2673.207
			2.57 x 0.50	24.9	40	2673.257
			3.07 x 0.50	31.9	40	2673.307
			4.14 x 0.50	40.0	40	2673.414
			5.14 x 0.50	51.2	40	2673.514
			6.14 x 0.50	60.5	40	2673.614
	U-lattice beam, with 4 wedge heads, aluminium		1.57 x 0.50	8.6	50	3206.157
			2.07 x 0.50	12.3	50	3206.207
			2.57 x 0.50	15.2	50	3206.257
			3.07 x 0.50	17.0	50	3206.307
			4.14 x 0.50	24.6	50	3206.414
6	O-lattice beam LW, with 4 wedge heads, steel		2.07 x 0.50	22.2	40	2674.207
			2.57 x 0.50	25.5	40	2674.257
			3.07 x 0.50	30.9	40	2674.307
			4.14 x 0.50	40.2	40	2674.414
			5.14 x 0.50	51.2	40	2674.514
			6.14 x 0.50	59.2	40	2674.614
			7.71 x 0.50	71.0	40	2674.771
7	U-ledger for lattice beam only in conjunction with Ref. No. 2656.000	0.73 m	0.73	3.1	42	4923.073
		1.09 m	1.09	7.8	42	4923.109
8	Spigot for U-section, only for uses without lift-off preventer			1.8	250	2656.000
9a	Spigot for U-lattice beam incl. 2 bolts. also for U-bridging ledger			2.1	250	2656.001
9b	Spigot for U-lattice beam, reinforced incl. 2 bolts			2.1	180	2656.002
10	Spigot for O-lattice beam with half-coupler for lattice beam and ledger	WS 19		1.8	250	4706.019
		WS 22		1.8	250	4706.022

WS = wrench size PU = packaging unit = available ex works = delivery time on request = only available in this packaging unit = the approval process is not yet completed

IND = Layher Individual possible – see page 7









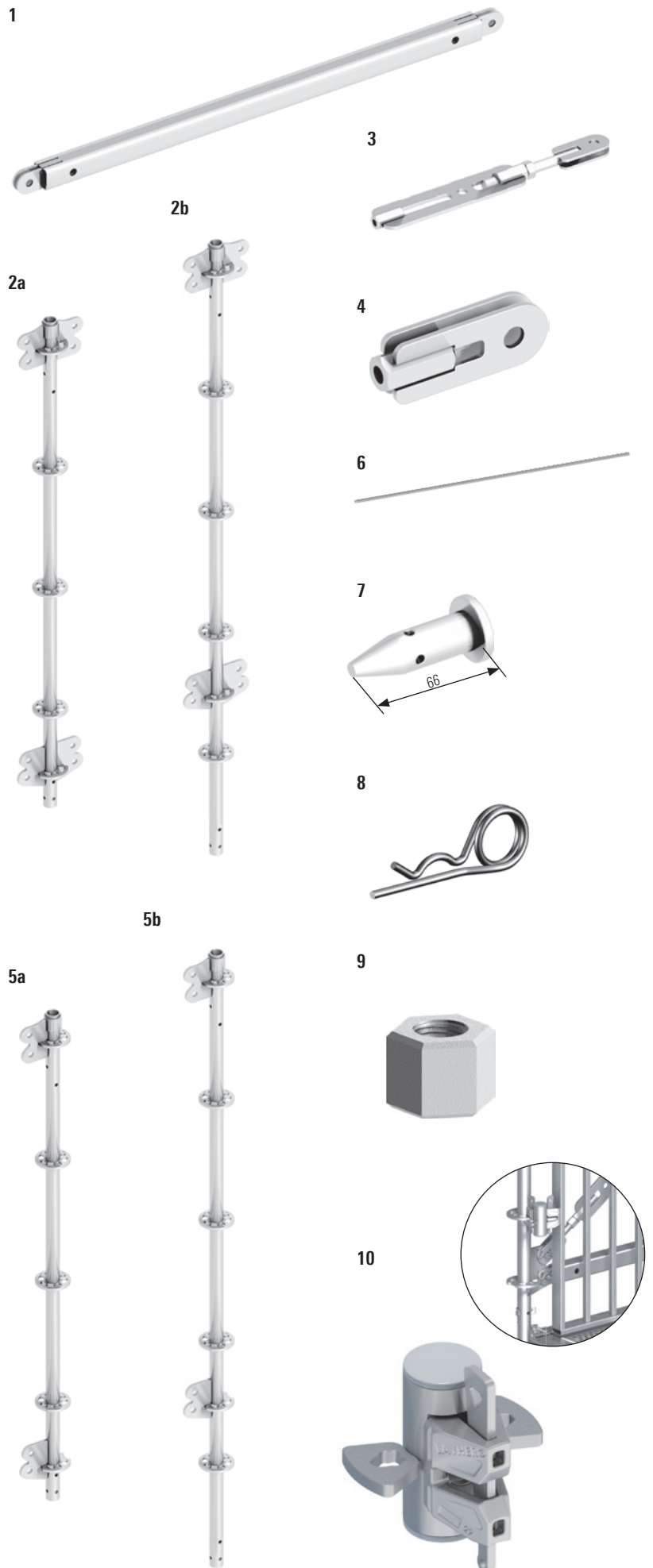
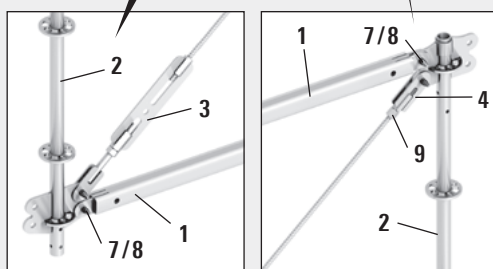
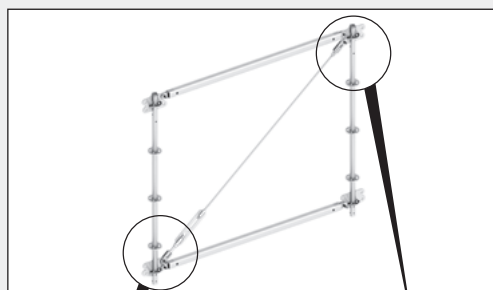
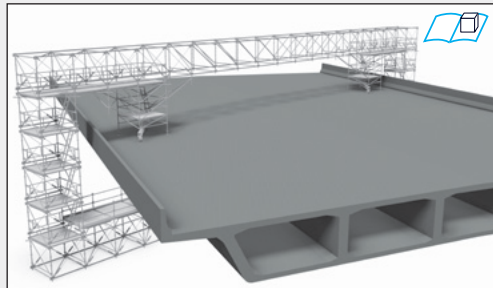

















FW System

To provide wide-span bridging too, or to support heavier loads, the Layher range now includes the **Allround FW System (FW)**. This additional Allround component is a modular-designed lattice beam of high load-bearing capacity that can be completely integrated into the Allround construction kit thanks to the standardised system dimensions. For lattice structures, only three essential supplementary components are needed, and they can be rapidly connected using pins: **an Allround FW post 2**, **a sturdy Allround FW chord 1** as the top and bottom chord, and a length-adjustable **Allround FW diagonal rod** consisting of **3/4/6/9**. A contribution to the high load-bearing capacity of the new product is made on the one hand by the use of efficient steel grades and the design height of the Allround FW System, and on the other hand by its installation in the Allround system standard dimension. This ensures a structurally advantageous and central force transmission – an offset is prevented.

A further special feature is the stepless adjustment of the diagonal rods using a **turnbuckle 3** – for example to build slightly higher structures. This compensates for unwelcome sagging. A crossed diagonal configuration is also possible for transmitting both positive and negative lateral forces.

The modular design of the Allround FW System not only permits flexible heights, widths and lengths for optimum adjustment to load and geometry requirements, but also ensures economical transport and assembly. This is thanks to bolt-free connection technologies and the low weight of the handy individual technologies, which is 19 kilograms maximum. If no crane is available at the site, the Allround FW System can be assembled manually without any problem – also in cantilevered construction from a secured level.



Pos.	Description	Dimensions L / H x W [m]	Weight approx. [kg]	PU [pcs.]	Ref. No.	
1	FW chord	1.57	10.5	20	2646.157 	
		2.07	13.9	20	2646.207 	
		2.57	17.4	20	2646.257 	
2a	FW post	1.00	12.6	28	2646.100 	
		1.50	15.4	28	2646.150 	
		2.00	17.2	28	2646.200 	
2b	FW post, extended for accessible bridgings	2.50	19.0	28	2646.250 	
3	FW endfitting with turnbuckle		3.8	250	2646.202 	
4	FW endfitting		1.0	500	2646.203 	
5a	FW post, single-side-connection for connection to the Allround Scaffolding in longitudinal direction	1.00	6.4	28	2646.105 	
		1.50	12.3	28	2646.155 	
		2.00	13.8	28	2646.205 	
5b	FW post, single-side connection, extended	2.50	16.6	28	2646.255 	
6	FW diagonal rod					
		for 2.57 x 2.00 m bay	2.37	3.3	20	2646.210 
		for 2.07 x 2.00 m bay	1.96	2.8	20	2646.211 
		for 2.57 x 1.50 m bay	2.07	2.9	20	2646.213 
		for 2.07 x 1.50 m bay and 1.57 x 2.00 m bay	1.63	2.4	20	2646.214 
		for 1.57 x 1.50 m bay	1.23	1.9	20	2646.215 
		for 2.07 x 1.00 m bay	1.40	2.1	20	2646.216 
	for 1.57 x 1.00 m bay	0.96	1.4	20	2646.217 	
7	Bolt, dia. 20 x 66 mm		1.6	10 	2646.221 	
8	Securing pin, dia. 4 mm		1.5	50 	5905.002 	
9	FW nut, WS 30 mm as counter nut for distortion lock while spanning		1.5	10 	2646.231 	
10	FW guardrail adapter for guardrail mounting		1.2	300	2646.001 	

WS = wrench size PU = packaging unit  = available ex works  = delivery time on request  = only available in this packaging unit  = the approval process is not yet completed

 = Layer Individual possible – see page 7

Bridging system

The **Allround bridging system** is the ideal complement to Layher Allround equipment. With just a few additional components, the load-bearing capacity of the proven Allround system can be increased enough to create, for example, wide-span footbridges or support structures for heavy loads.

The Allround bridging system is available in the familiar Layher dimensions of 2.07 m and 2.57 m, with its unique wedge head connection making it fully compatible with Layher Allround equipment. Simple bolt connections enable the components of the bridging system to be connected up, resulting in quick and easy assembly.

When used as a support beam for a scaffolding structure, podium or roof structure, the Allround bridging system is connected to the structure above it by using Allround standards integrated into the top. Using the wedge heads welded onto the sides, even suspended scaffolding structures can be connected, or several bridging units can be connected next to one another for a further increase in the load bearing capacity.

When a footbridge is built, the Allround bridging system is connected to Allround standards using the wedge heads provided on the sides of the posts. Depending on application, either Event decks or steel decks can be used. The bridge can also be clad using Layher Protect cassettes and roofed. The bridge is mounted on Layher heavy-duty columns with specially designed support elements. These support elements permit pre-assembly on the ground and subsequent insertion by crane, which is a major advantage when spanning bridges across roads.

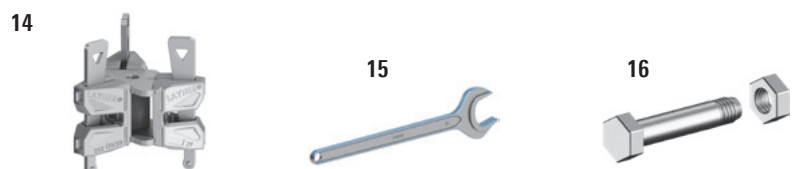
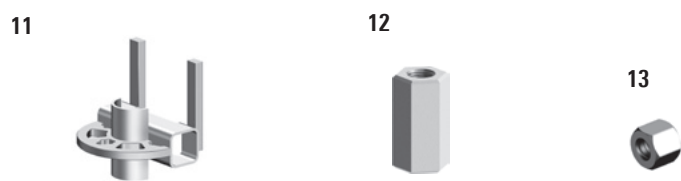
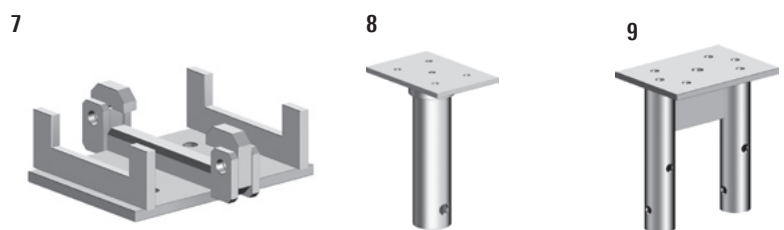
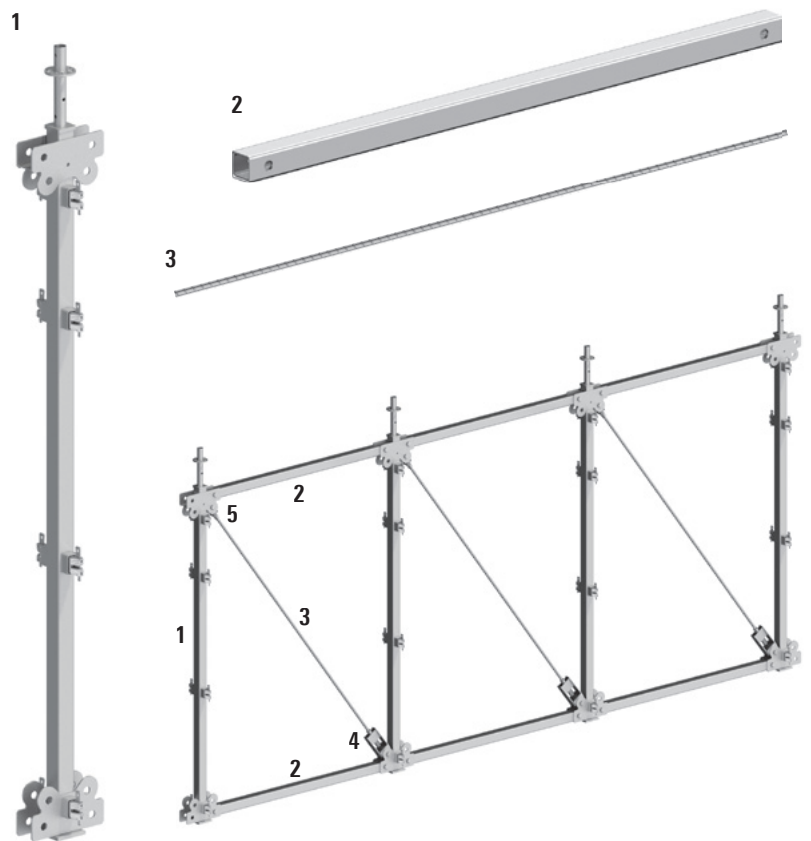
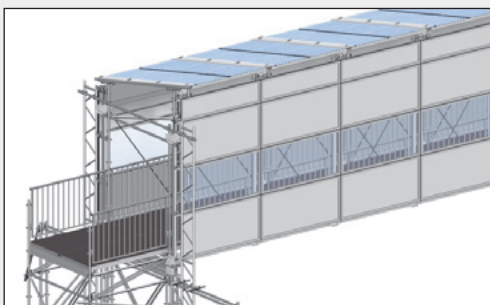
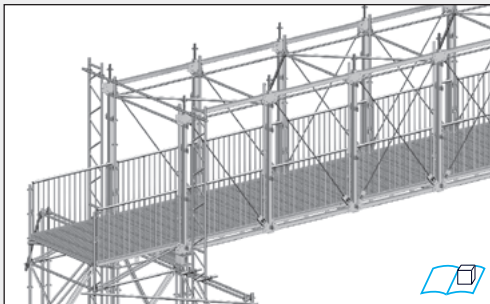

Pos.	Description	Dimensions L / H x W [m]	Weight approx. [kg]	PU [pcs.]	Ref. No.
1	Bridging system post	3.22	57.3	18	2671.000
2	Bridging system chord for 2.07 m bay length for 2.57 m bay length	1.97	20.8	45	2671.010
		2.47	25.8	45	2671.020
3	Bridging system diagonal rod for 2.07 m bay length for 2.57 m bay length	3.05	7.9	75	2671.030
		3.37	8.7	75	2671.040
4	Bridging system diagonal anchoring, without nut		5.5	300	2671.050
5	Bridging system diagonal anchoring, with nut		2.9	300	2671.060
6	Bolt, dia. 30 x 145 mm		8.0	10	2671.072
	Securing pin dia. 4 mm		1.5	50	5905.002
7	Bridging system support element		4.8	80	2671.080
8	Bridging system adapter for heavy-duty column		5.5	124	2671.090
9	Bridging system support for double standard		4.9	50	2671.140
10	Bridging system support beam for bridge width 1.57 m for bridge width 2.07 m for bridge width 2.57 m		119.2	4	2671.095
			145.8	4	2671.100
			167.0	4	2671.105
11	Protect holder		1.0	250	2671.110
12	Clamping nut for diagonal rod, WS 36 x 70, galvanized		4.0	10	2671.122
13	Locking nut for diagonal rod, WS 36 x 70, galvanized		4.0	20	2671.132
14	Wedge-head coupler, triple		2.3	25	2671.150
15	Open ended wrench WS 36		0.5	5	2671.135
16	Hexagon head bolt M12 x 35, with nut		5.0	50	2671.162

WS = wrench size PU = packaging unit = available ex works = delivery time on request = only available in this packaging unit = the approval process is not yet completed

= Layher Individual possible – see page 7

FlexBeam

Rapid assembly and optimum use of materials ensure economical scaffolding structures. The aluminium **FlexBeam** makes it possible. It enables surface scaffolding to be efficiently assembled both suspended and upright.

Because when compared with the steel lattice beam 450:

- ▶ the **bending load capacity is up to 2.5 times higher**, meaning that larger support and suspension configurations are possible.
- ▶ the **structural height with just 280 mm is about 40% lower**, resulting in lower construction heights and thus expanded possibilities for use.
- ▶ as a rule **no compression chord bracing** is required.
- ▶ a channel-shaped upper side of the section is provided for **direct suspension of U-system decks** which are also secured in position by the use of a new and easy-to-fit lift-off preventer.

Further expansion using standard Allround components is also possible. In the case of use as suspended scaffolding the **anchor plate 3** and the **suspension shoe 4** are available for receiving the beam. The **anchor plate 3** is intended for direct wall-plug connection to the structure.

The **suspension shoe 4** can be directly connected to the **tie rod adapter 5**. Optionally the suspension can be extended in length by Allround standards using the **standard adapter (male/female) 6/7**. The tie rod adapter is used for connection to a tie rod firmly anchored in the structure and suitable for this purpose.

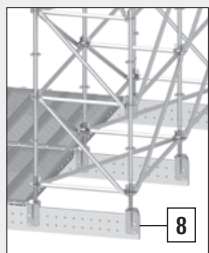

The **standard connector 8** is used for expansion within the Layher system dimensions. The **lift-off preventer 10** can be inserted anywhere and moved in the longitudinal direction of the beam. The lift-off preventer is fixed in place with the **lift-off preventer bolt 12**.

To extend the length of beams the **FlexBeam spigot 1** is available, which is inserted into the hollow chamber of the beam section and then pinned to the beam.

The timber beam support permits lateral fitting of an extra beam, for example to act as a basis for providing fitted bays in curved sections.

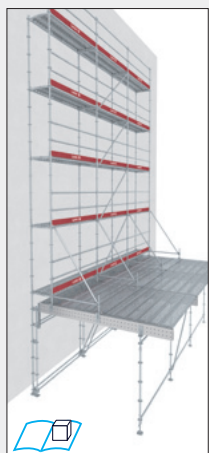

The **front beam adapter 17** permits connection of the FlexBeam end to an Allround standard at the system level. It offers adjustment possibilities in both the vertical and horizontal directions. The decking protects pedestrians from falling items.

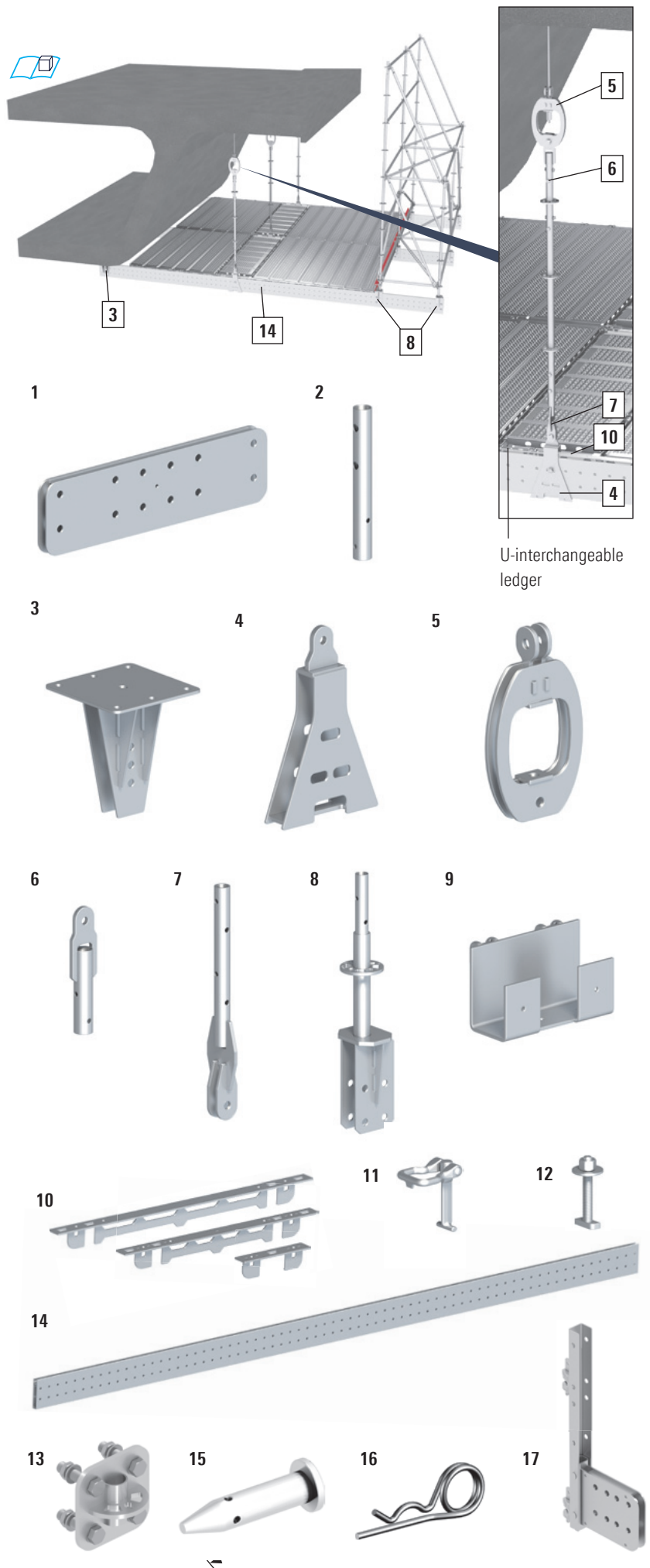

U-interchangeable ledger

Pos.	Description	Dimensions L / H x W [m]	Weight approx. [kg]	PU [pcs.]	Ref. No.
1	FlexBeam beam spigot for stiff connections of FlexBeams		16.4	50	2657.010
2	FlexBeam anchor plate tube		1.3	200	2657.020
3	FlexBeam anchor plate		12.0	50	2657.030
4	FlexBeam suspension shoe vertical bearer for the FlexBeam		9.3	50	2657.040
5	FlexBeam tie rod adapter as connection between Allround standards (w / o spigot) to the diagonal rod		5.7	100	2657.050
6	FlexBeam standard adapter male for further construction with Allround standards (w / o spigot)		1.7	300	2657.060
7	FlexBeam standard adapter female for connection between Allround standard and suspension shoe		2.9	300	2657.070
8	FlexBeam standard connector for protective wall structures		6.6	100	2657.080
9	FlexBeam timber beam support use for e.g. trapeziform adjustment bays		3.4	150	2657.090
10	FlexBeam lift-off preventer	0.26	0.7	50	2657.026
		0.76	2.2	50	2657.076
		1.00	3.3	50	2657.100
11	FlexBeam lift-off preventer lock		8.1	50	2657.111
12	FlexBeam lift-off preventer bolt		2.8	20	2657.121
13	FlexBeam rosette adapter for the lateral connection of Allround O-ledgers and horizontal diagonal braces to the beam. Including 4 bolts and nuts		2.7	150	2657.130
14	FlexBeam Alu U-beam	3.00	30.0	12	2657.300
		4.00	40.0	12	2657.400
		5.00	50.0	12	2657.500
		6.00	60.0	12	2657.600
		7.00	70.0	12	2657.700
15	Bolt, dia. 20 x 113 mm		3.0	10	2646.281
16	Securing pin, dia. 4 mm		1.5	50	5905.002
17	FlexBeam end bracket adapter for connection to an Allround standard in system level at beam end		11.8	20	2657.015

WS = wrench size PU = packaging unit = available ex works = delivery time on request = only available in this packaging unit = the approval process is not yet completed

IND = Layher Individual possible – see page 7

FlexBeam

The **cross-connector 1** allows FlexBeams, positioned one above the other and at right angles, to be turned into a grid structure. Special structures produced specifically for projects – e.g. welded steel structures – can simply be replaced by them, not only resulting in economic benefits but also saving on raw material resources.

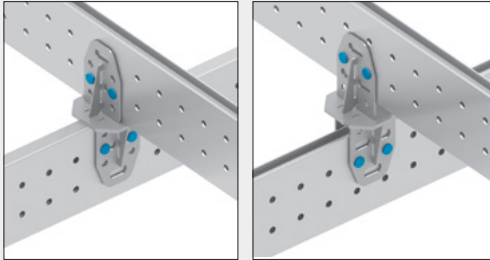

Securing positions of beams

Suspended beams

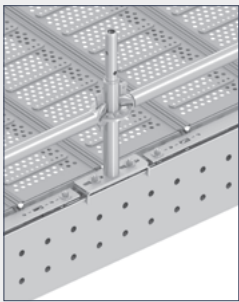

Using existing Allround system components to provide side protection on the FlexBeam permits economical system solutions without the need for costly improvisation. Where necessary the **guardrail adapter 2** can also be used as a connecting piece for elevated scaffolding.

Allround Wall Bracket

A wall bracket is used in scaffolding construction to support scaffolding on the facade. The conventional and previously known brackets are steelwork-based designs made from, for example, I-sections which are heavy and awkward to handle. This greatly hinders assembly.

The new Allround wall bracket – consisting of the **wall connection unit 3** and **pressure support 4** – is by contrast lightweight, small and handy. That makes it ideal for quick attachment to the facade. In combination with the components from the Allround construction kit, they enable a wide range of possible configurations to be created. Building of the facade scaffolding can continue using both Allround components and the advancing Allround Guardrail System (ARGS).

If one or more wall brackets cannot be arranged on the wall in the axis dimension of the scaffolding structure (e.g. in the case of window openings), or to further reduce the assembly effort, the Aluminium FlexBeam can be used to absorb the loads.

The transition between the wall bracket and the Aluminium FlexBeam is created with a **FlexBeam crosspiece 5** and the **cross-connector 1**.

The scaffolding is mounted on the Aluminium FlexBeam, using the **base plate support 6**.



Depending on the position of the guardrail adapter 2, a different configuration with lift-off preventers is chosen:

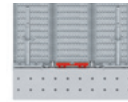

Standard spacing 0.73 m
1 x lift-off preventer 0.26 m



Standard spacing 1.09 m
1 x lift-off preventer 0.76 m



Standard spacing 2.07 m
1 x lift-off preventer 1.00 m, 1 x lift-off preventer 0.76 m



Standard spacing 2.57 m
2 x lift-off preventer 1.00 m, 1 x lift-off preventer 0.26 m







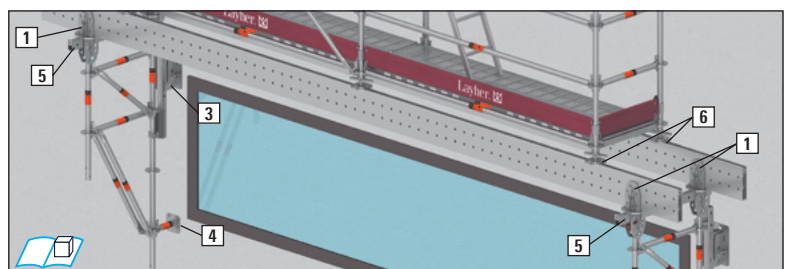
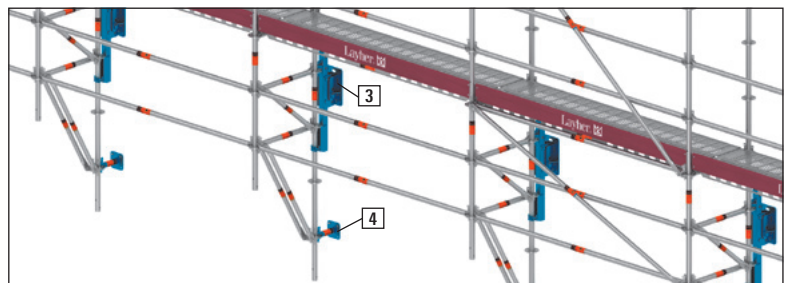
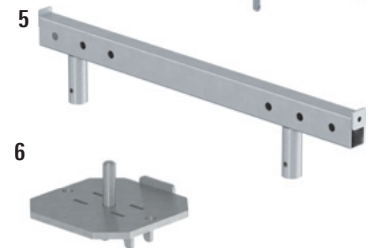

Standard spacing 3.07 m
2 x lift-off preventer 1.00 m, 1 x lift-off preventer 0.76 m



The wall connection unit can be dismantled completely.



Pos.	Description	Dimensions L/H x W [m]	Weight approx. [kg]	PU [pcs.]	Ref. No.
1	FlexBeam cross-connector		10.4	30	2657.140 
2	FlexBeam guardrail adapter		3.8	100	2657.085 

Pos.	Description	Dimensions L/H x W [m]	Weight approx. [kg]	PU [pcs.]	Ref. No.
3	Allround wall connection unit		25.8	40	2632.500 
4	Allround pressure support		4.7	100	2632.501 
5	FlexBeam crosspiece	0.73	7.1	50	2657.073 
6	Base plate support		1.8	100	2657.150 

WS = wrench size PU = packaging unit  = available ex works  = delivery time on request  = only available in this packaging unit  = the approval process is not yet completed

IND = Layher Individual possible – see page 7

STAR frame

The great advantage of the **STAR frame** is its unrestricted integration into the existing Allround module system.

That means:

- ▶ Only one system for both facade and industrial scaffolding.
- ▶ Rapid assembly and new possibilities for using the Allround equipment.
- ▶ Use of the STAR frame in conjunction with basic components of the Allround equipment.

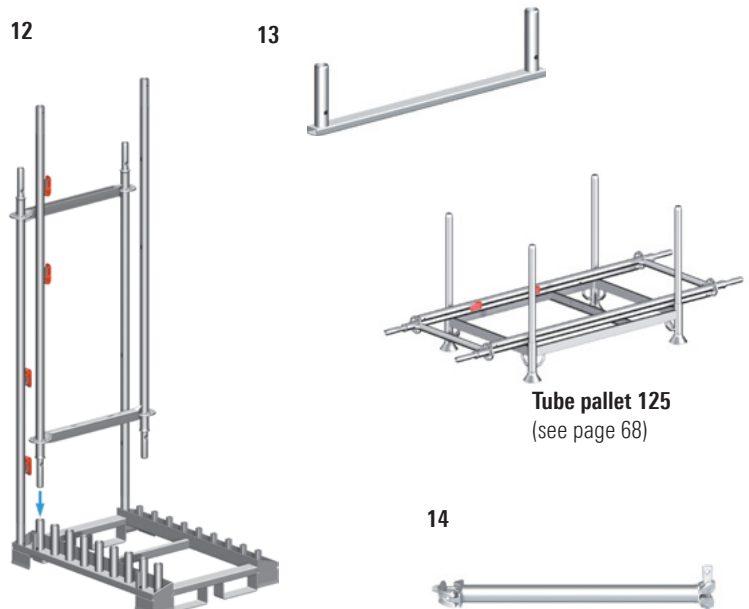
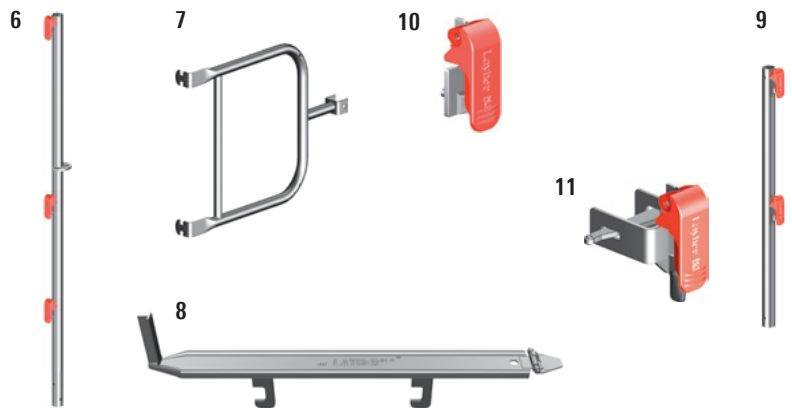
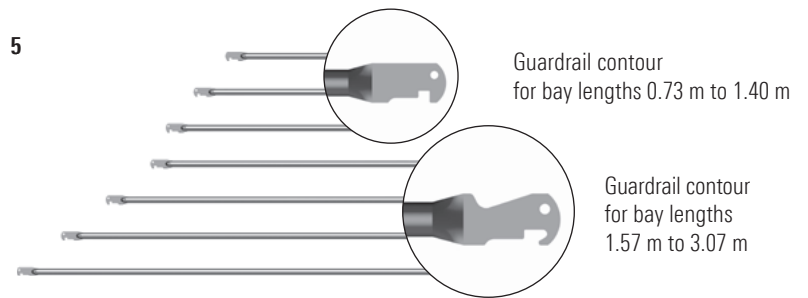
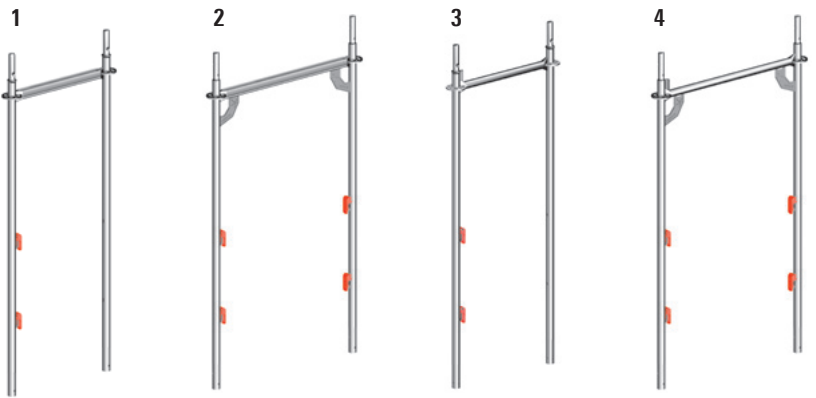

Tube pallet 125
(see page 68)



Perfect compatibility
with the Allround system

Revolutionary, the new
guardrail attachment
– rapid assembly
without tools and
increased safety thanks
to rapid recognition of
the closed state thanks
to the red bar.

Pos.	Description	Dimensions L/H x W [m]	Weight approx. [kg]	PU [pcs.]	Ref. No.	
1	U-STAR frame , Standard frame 2.00 x 0.73 m	2.00 x 0.73	19.0	22	2602.059	
2	U-STAR frame LW , Standard frame 2.00 x 1.09 m	2.00 x 1.09	23.6	22	2602.056	
3	O-STAR frame LW , Standard frame 2.00 x 0.73 m	2.00 x 0.73	17.5	22	2602.060	
4	O-STAR frame LW , Standard frame 2.00 x 1.09 m	2.00 x 1.09	21.8	22	2602.057	
5	STAR guardrail lightweight guardrail made of 33.7 mm tube. Assembly without tools ensures rapid installation and removal.	0.73	1.4	140	2602.005	
		1.09	2.0	140	2602.006	
		1.40	2.6	140	2602.007	
		1.57	2.9	140	2602.061	
		2.07	3.7	140	2602.062	
		2.57	4.5	140	2602.063	
		3.07	5.5	140	2602.064	
6	STAR roof guard support		7.2	28	2602.020	
7	STAR double end guardrail closure of the scaffolding at its end. This permits the use of internal guardrails up to the end.	0.73 m	0.73	4.3	60	2602.014
		1.09 m	1.09	5.6	50	2602.018
8	STAR lift-off preventer The welded-on toe board pin requires the use of the lift-off preventer before the toe boards as specified can be installed at the working levels, (only necessary for STAR U-frame)	0.73 m	0.73	1.4	300	2602.015
		1.09 m	1.09	2.1	150	2602.017
9	STAR guardrail support , top scaffolding closure	1.00	4.7	50	2602.013	
10	STAR internal guardrail fixing device rapid tool-less assembly by swinging in the bar. for the connection of internal guardrails		0.3	50	2602.012	
11	STAR guardrail adapter for lateral guardrail connection of STAR and Allround system		0.6	50	2602.016	
12	STAR pallet , without parts 19 STAR frames (0.73 m wide) loading capacity with vertical storage and transport in the STAR pallet	1.20 x 0.91	42.3	10	5113.001	
13	STAR transport safeguard prevents the STAR frames (0.73 m wide) from being pulled together on the truck when being secured. This ensures safe transportation. The top frame is secured with pins.	0.80	2.4	200	6309.001	
14	STAR O-ledger with half-coupler end guardrail in prepositioned platform access bay	WS 19	0.73	3.2	400	2601.074

WS = wrench size PU = packaging unit = available ex works = delivery time on request = only available in this packaging unit = the approval process is not yet completed

IND = Layher Individual possible – see page 7

Shoring TG 60

The **shoring TG 60** ensures a fast, flexible and safe assembly of shoring towers. The Allround shoring TG 60 is able to bear **up to 6 tons per standard**.

The structural analysis of the Allround shoring TG 60 complies to DIN EN 12812.

The heart of the TG 60 are the **shoring frames TG 60** with integrated rosettes. All frames are symmetrical parts, thus the orientation of the diagonal braces can be varied.

The adaptation to the dimension of the formwork beams can be easily made by using different Allround ledgers and diagonal braces from 1.09 m to 3.07 m (see figure "bay length adaptation").

Thanks to the perfect compatibility to Allround Scaffolding, the towers of the TG 60 can be adapted flexibly to any building condition.

The shoring tower TG 60 can be assembled in horizontal position on the ground. Then the tower will be placed by crane. Otherwise it can be assembled in vertical position – optionally directly at the place of action or somewhere else, with placing it with its quickly mounted **castors**.



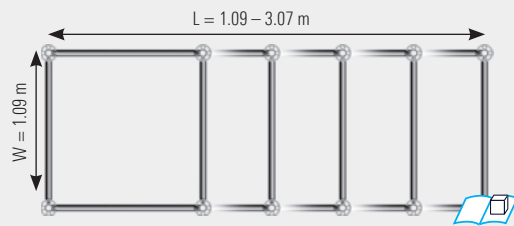





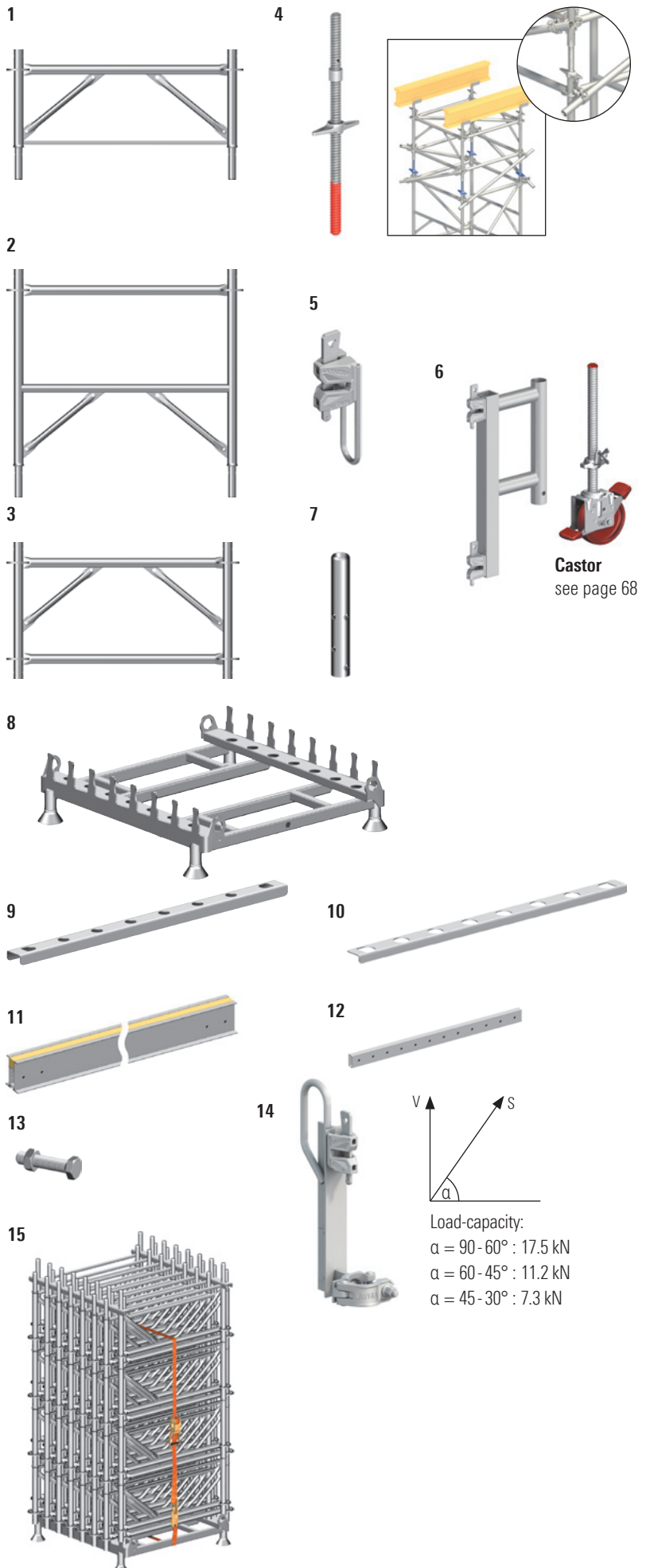









The Allround shoring TG 60 has an integrated advanced guardrail without any accessories for assembly in vertical position. For the Allround shoring TG 60, only solid base plates (see page 10) may be used.



Bay length adaptation with Allround serial ledgers from 1.09 m to 3.07 m.

Further information about the Allround Shoring TG 60 can be found in the product video: yt-tg60-en.layher.com



Pos.	Description	Dimensions L / H x W [m]	Weight approx. [kg]	PU [pcs.]	Ref. No.	
1	Shoring frame TG 60 spacer frame; with spigot at the bottom steel, hot-dip galvanized	0.50 x 1.09	13.0	21	2602.036 	
2	Shoring frame TG 60 standard frame; with spigot at the bottom steel, hot-dip galvanized	1.00 x 1.09	17.7	21	2602.035 	
3	Shoring frame TG 60 base frame, without spigot; steel, hot-dip galvanized	0.71 x 1.09	15.9	21	2602.034 	
4	Intermediate jack for high adjustment or inclined ceilings	0.80	8.3	100	2602.038 	
5	Spindle support for placement by crane or by castors steel, hot-dip galvanized		0.8	25	2602.033 	
6	Castor adapter with 2 wedge heads		6.4	50	2602.040 	
7	Shoring spigot for use of the initial frame as tower head, spigot is secured with 2 hinged pins		1.1	350	2602.032 	
8	Shoring frame pallet for use with 22 shoring frames each level, stackable, craneable, optimized for truck beds	1.20 x 1.10	53.7	10	5113.003 	
9	Loading and stacking securing profile for use at the stack head with upwards pointing spigots	1.20	3.9	50	5113.004 	
10	Loading and stacking securing profile for use at the stacking head without upwards pointing spigots (e.g. for stacking of initial frames)	1.20	3.4	10	5113.005 	
11	Aluminium section beam with wood , with riveted-in wood section, with holes drilled for connection by means of beam connectors	3.00 m long	3.00	18.0	48	4026.300 
		4.00 m long	4.00	24.0	48	4026.400 
12	Beam connector , 1.20 m	1.20	6.6	100	4026.000 	
13	Beam connector bolt , M12 x 70, with nut		0.7	10 	4026.003 	
14	Fastening for crane transport		3.4	100	2630.000 	
15	Shoring TG 60 frame set consisting of 88 shoring frames Pos. 1 on frame pallet Pos. 8		1,205.5		2602.043 	
	Shoring TG 60 frame set consisting of 44 shoring frames Pos. 2 on frame pallet Pos. 8		840.3		2602.041 	
	Shoring TG 60 frame set consisting of 22 shoring frames Pos. 3 on frame pallet Pos. 8		410.3		2602.042 	

WS = wrench size PU = packaging unit  = available ex works  = delivery time on request  = only available in this packaging unit  = the approval process is not yet completed

IND = Layher Individual possible – see page 7

Heavy-duty column

An extremely high load-bearing capacity is achieved by combining four Allround standards. Specially developed top and base pieces, and heavy-duty spindles fitted into the latter, permit a multiplication of the individual load capacities of each standard.

These individual elements can then be expanded, with the aid of further Allround standard elements, into any spatial structures required.

Load-bearing capacities as **single support**, **double support** or **tower**, you can get upon request.

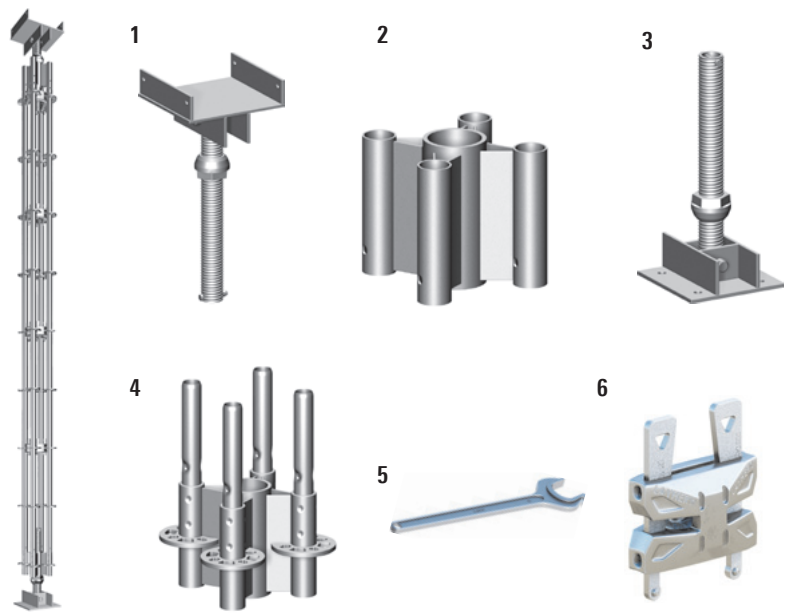

Heavy Duty Tower XL

For construction projects where very high loads have to be transmitted at some points, for example in bridge building, shoring of particularly high load capacity is needed. Heavy shoring structures using steel sections are frequently used here.

With the Allround Heavy Duty Tower XL, Layher is now offering a modular and system-integrated shoring tower based on standard Allround Scaffolding parts.

With a few lightweight components supplementing the proven Allround Scaffolding construction kit, load capacities in the mega newton class are attained, yet easy to handle for better logistics and assembly – even when no crane is available – and permitting integrated work platforms and accesses within the system.

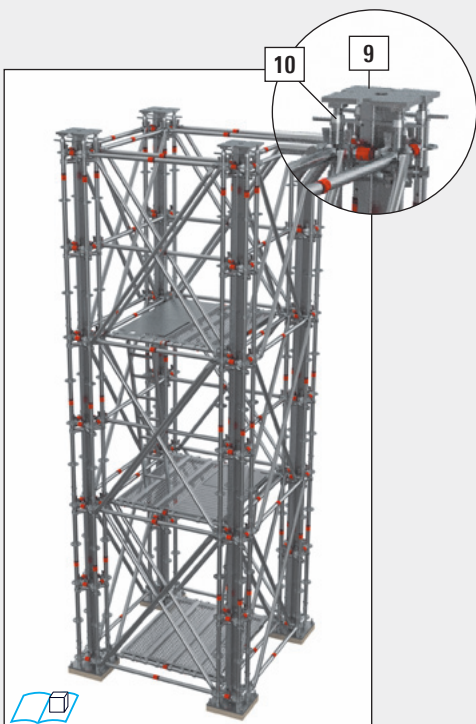
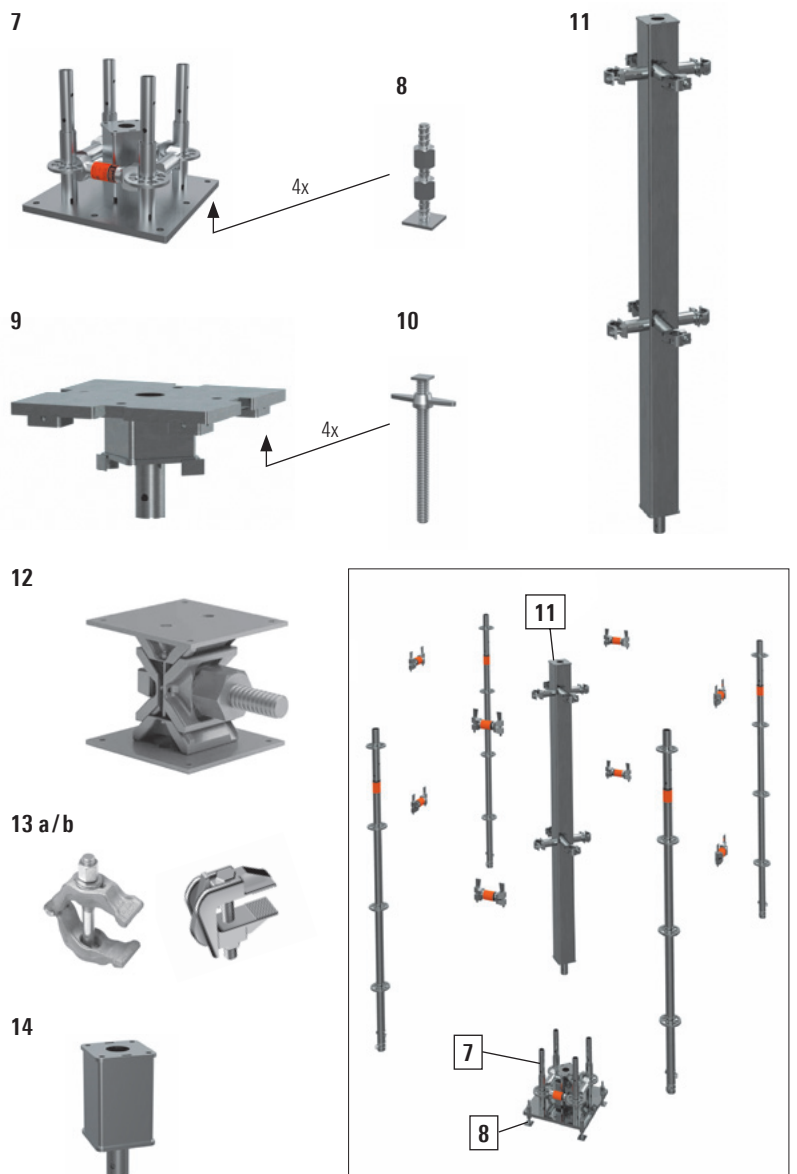

Pos.	Description	Dimensions L/H x W [m]	Weight approx. [kg]	PU [pcs.]	Ref. No.
1	Head jack for heavy-duty column	0.70	30.9	25	5312.004
2	Head part for heavy-duty column	0.21	7.1	100	5312.003
3	Base plate for heavy-duty column	0.70	24.1	40	5312.001
4	Base piece for heavy-duty column	0.40	11.5	48	5312.002
5	Single open-end wrench, WS 95	0.60	7.0	5	5312.005
6	Twin wedge coupler		1.2	25	2629.000

Pos.	Description	Dimensions L/H x W [m]	Weight approx. [kg]	PU [pcs.]	Ref. No.
7	Base plate	0.45 x 0.45	46.9	4	2612.000
8	Adjustable foot		6.0	20	2612.005
9	Head plate	0.30 x 0.30	21.7	4	2612.002
10	Head jack		3.0	250	2612.003
11	Profil	0.50	13.5	50	2612.050
		1.00	21.0	25	2612.100
		1.50	32.5	20	2612.150
		2.00	40.0	8	2612.200
12	Lowering wedge, 1000 kN		53.3	12	2612.004
13a	Beam clamp, clamping width 5 to 70 mm, with approval Z-8.34-873		1.6	500	5310.001
13b	Beam clamp, clamping width 12 to 50 mm		1.5	450	5310.000
14	Compensation element	0.20	5.0	50	2612.020

WS = wrench size PU = packaging unit = available ex works = delivery time on request = only available in this packaging unit = the approval process is not yet completed

= Layher Individual possible – see page 7

Modular stairtower

Layher has now further optimized the use of the All-round system as a scaffolding stairtower – assembled from standard scaffolding components and prefabricated stairways with integrated platforms.

Thanks to a newly developed 2.21 m long vertical Allround standard (see page 12), this tower can now be preassembled as required, on the ground and section by section, before being moved by crane to form a tower with unidirectional or alternating stairways. Construction companies benefit in this way from an even easier, faster and above all safer assembly and modification, and from an increased height clearance of 2.20 m that makes its use even more convenient.

The advantages over expensive one-off structures or ad-hoc solutions made of timber are persuasive: rapid and economical assembly, optimum conditions for construction workers thanks to a high degree of safety during use, and exact matching to existing conditions.

For securing of every floor, hinged pins are used (see page 12).

For the Allround modular stairtower, a type testing for assembly heights up to 115 m is available.

ADDITIONAL EQUIPMENT FOR END MODULE (O-VERSION)

Description	PU [pcs.]	Ref. No.
Internal stairway guardrail 1.50 m*	1	1752.012
Standard LW 1.00 m	4	2617.100
O-ledger LW 1.40 m	4	2601.140
O-ledger LW 2.57 m	4	2601.257
Guardrail post 1.30 m	1	2638.400
O-ledger LW 1.90 m with wedge head and U-fork	2	2638.401
O-steel deck T9 2.57 x 0.32 m	2	3862.257

* only for alternating assembly

STAIRWAY MODULE, UNIDIRECTIONAL (O-VERSION)

Description	PU [pcs.]	Ref. No.
O-comfort stairway 2.57 x 0.65 m	1	2635.257
Stairwell guardrail 1.00 x 0.50 m, WS 19	1	1752.004
Internal stairway guardrail	1	1752.007
Initial standard LW 2.21 m	4	2617.221
O-ledger LW 1.40 m	8	2601.140
O-ledger LW 2.57 m	8	2601.257
Diagonal brace LW 1.40 x 2.00 m	2	2683.140
Diagonal brace LW 2.57 x 2.00 m	2	2683.257
O-steel deck T9 2.57 x 0.32 m	2	3862.257

Compact stairtower

In its standard version, the compact stairtower conforms to German regulations on "stairways for building work" and fits into many stairway recesses in buildings to house one or more families.

The stairway can be integrated into Allround work scaffolding. The use of standard parts means that only a few additional parts are needed.

Surface area without brackets 1.57 x 1.40 m.
Exit clearances: 2.50 or 2.75 or 3.00 m possible.

Permissible load capacity: 2.0 kN / m²

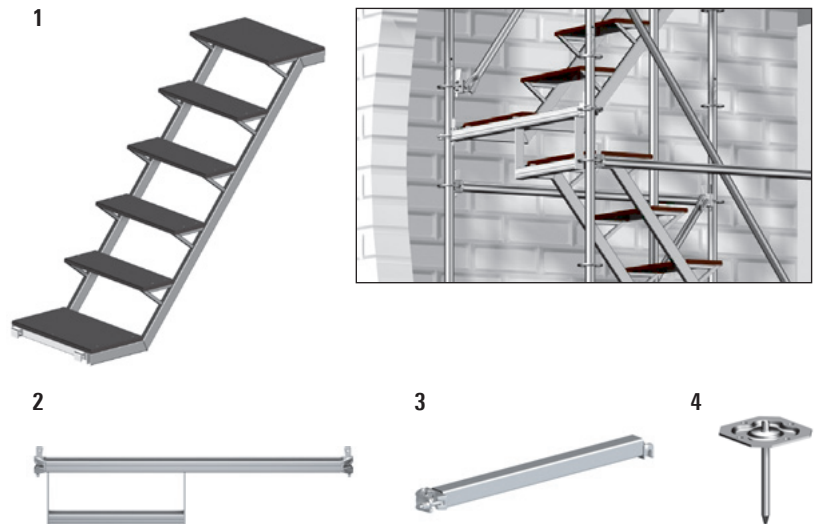

Hollow wall bracket

The hollow wall bracket allows concreting work on prefabricated element walls. Forget about time-consuming timber structures – simply suspend the bracket from the top of the wall and lay system decks on it – that's all.

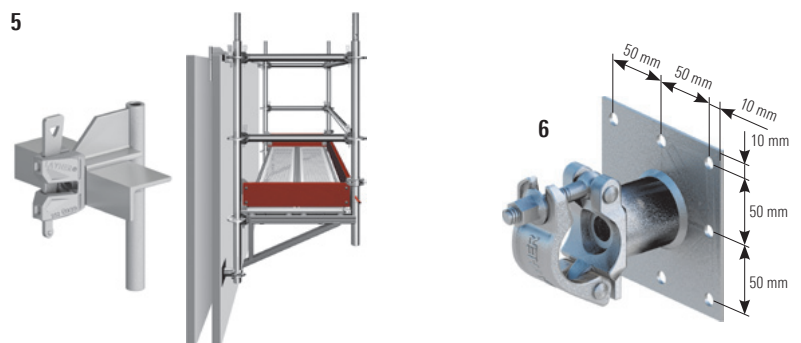

STAIRWAY MODULE, ALTERNATING (O-VERSION)

Description	PU [pcs.]	Ref. No.
O-comfort stairway 2.57 x 0.64 m	1	2635.257
Internal stairway guardrail WS 19	1	1752.007
Initial standard LW 2.21 m	4	2617.221
O-ledger LW 1.40 m	6	2601.140
O-ledger LW 2.57 m	9	2601.257
Diagonal brace LW 1.40 x 2.00 m	2	2683.140
Diagonal brace LW 2.57 x 2.00 m	2	2683.257

BASE

Description	PU [pcs.]	Ref. No.	Art.-Nr.
Base plate 60	4	4001.060	
Spindle support	4	2602.033	







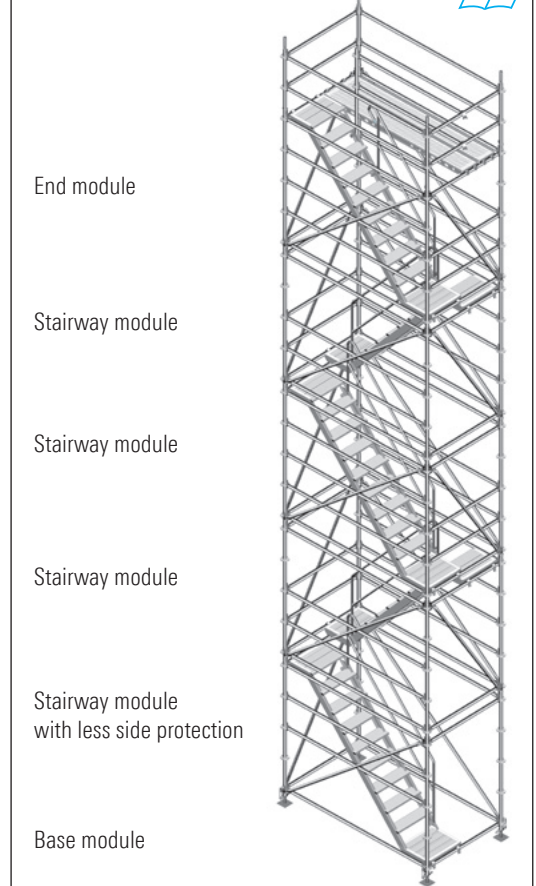

Further information about the Allround Modular Stairtower can be found in the product video: yt-armtt-en.layher.com



ALTERNATING VERSION



Pos.	Description	Dimensions L/H x W [m]	Weight approx. [kg]	PU [pcs.]	Ref. No.
1	U-stair , 1.25 x 0.60 m, steel for 1.57 m bay, step height 0.25 m	1.25 x 0.60	32.5	12	2636.125 
2	U-ledger with bearer , 1.40 m for compensating 25 cm, see detailed sketch on left	1.40	9.0	50	2618.141 
3	Gap cover , 0.79 m	0.79	3.4	100	2636.078 
4	Adapter plate , steel When placing the compact stair tower onto this adaptor plate, it is easily possible to lay the screed.	0.15 x 0.15 x 0.20	1.3	100	2636.124 

Pos.	Description	Dimensions L/H x W [m]	Weight approx. [kg]	PU [pcs.]	Ref. No.
5	Hollow wall bracket adapter steel, hot-dip galvanized		2.3	200	2602.400 
6	Half-coupler with plate for supporting the scaffolding structure against the wall	WS 19 0.12 x 0,12	1.5	25	4705.019 

WS = wrench size PU = packaging unit  = available ex works  = delivery time on request  = only available in this packaging unit  = the approval process is not yet completed

IND = Layher Individual possible – see page 7

Flat roof side protection

According to German regulations DGUV 101-038 relating to construction work, a fall protection system must be provided for work areas and walkways on roofs where the height of the fall is more than 3.00 m. The flat roof guardrail meets these requirements for safeguarding flat roofs. A few parts (e.g. **flat roof guardrail post 1**, **flat roof shift preventer 4**, **flat roof guardrail stiffener 3**, **flat roof ballast 19 kg 7**, **support for flat roof guardrail 6**, **wheel set and toe board support 2**) in addition to the already provided ledgers enable variable fall protection systems to be assembled quickly and easily. The maximum ledger length between two **flat roof guardrail posts 1** is 3.07 m.

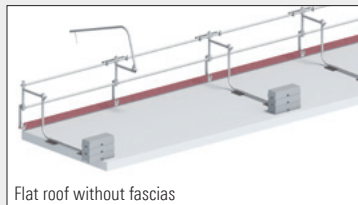

Flat roof without fascias

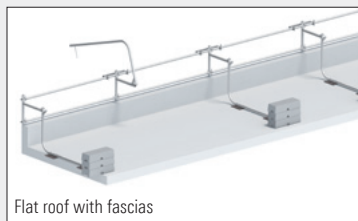

Flat roof with fascias

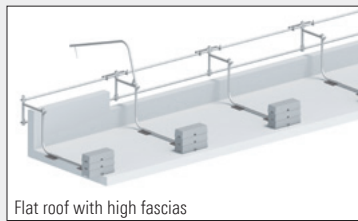

Flat roof with high fascias



Flat roof side protection mobile

Always comply with instructions for assembly and use.

Advance guardrail system

The **advance guardrail post 10**, the **telescoping assembly guardrail 1.57/2.07 m**, the **telescoping assembly guardrail 2.07/3.07 m 11**, and the **End-AGS 12** are used for temporary protection against falls during assembly of scaffolding parts on the uppermost, unsecured scaffolding level.

Extension lengths

Article	L min.	L max.
Advance guardrail 1.57/2.07 m	1.57 m	2.90 m
Advance guardrail 2.07/3.07 m	2.07 m	3.70 m

Stocking and transport

One tube pallet 125 and 6 steel decks resp. 3 Robust- or Xtra-N decks can be used together with the **end plates for transport box 14** as a practical transport box. This can be used for protectively stocking and transport of the AGS.

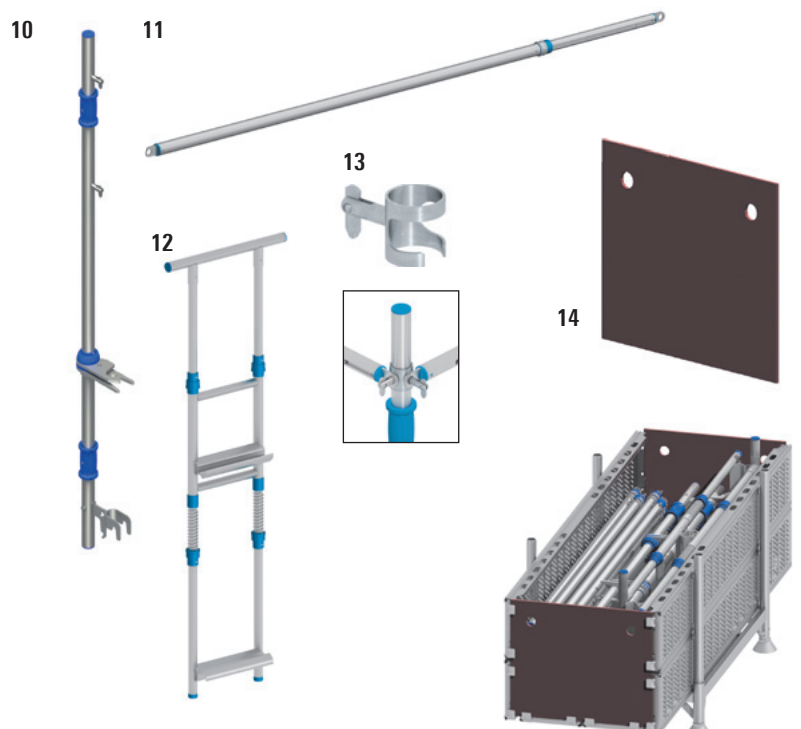

More information about the AGS, you can find in the product film: yt-msg-en.layher.com

Pos.	Description	Dimensions L/H x W [m]	Weight approx. [kg]	PU [pcs.]	Ref. No.
1a	Flat roof guardrail post steel, for low roof edges	2.40	13.7	20	2666.010
1b	Flat roof guardrail post, offset steel, for high roof edges	2.70	15.8	20	2666.011
2	Flat roof wheel set	0.60 x 0.50	6.4	20	2666.015
3	Flat roof guardrail stiffener steel	0.60	4.1	60	2666.030
4	Flat roof shift preventer steel	0.50	1.9	60	2666.020
5	Standard lock, 0.50 m	0.58	4.0	100	2603.000
6	Support for flat roof guardrail	0.30 x 0.23	0.6	400	2666.050
7	Flat roof ballast 19 kg	0.69 x 0.25 x 0.16	19.0	50	2666.060
8	Ballast (10 kg) from steel, hot-dip galvanized with half-coupler		10.0	100	1249.000
9	Flat roof toe board support	0.04 x 0.13 x 0.13	0.7	300	2666.070

Pos.	Description	Dimensions L/H x W [m]	Weight approx. [kg]	PU [pcs.]	Ref. No.
10	Advance guardrail post T19 , aluminium for two advance guardrails (0.50 m and 1.00 m height); rapid guardrail assembly with a tilting pin		6.0	50	4031.003
11	Assembly guardrail T19 , 1.57/2.07 m, aluminium, telescopic Assembly guardrail T19 , 2.07/3.07 m, aluminium, telescopic	1.70	2.9	50	4030.207
		2.30	3.7	50	4030.307
12	End-AGS , aluminium for securing the scaffolding end for bay width of 0.73 m to 1.40 m	2.20 x 0.70	9.8	5	4031.000
13	Tilting pin adapter for use of the AGS at outer and inner corners		0.3	10	4031.005
14	End plate for transport box plywood, easy fixation by the u-claws of the scaffolding decks	0.72 x 0.60	2.4	120	5105.072



The advance guardrail system (AGS) can be used for the access bay or over several bays.

The instructions for assembly and use of the Allround Scaffolding System must be complied with.

Detail of assembly of the AGS in the access bay



The End-AGS is used by placing the bottom U-section on the lower guardrail. The upper U-section must be pulled down to fit into place under the deck ledger. By letting go the End-AGS will be secured.

WS = wrench size PU = packaging unit = available ex works = delivery time on request = only available in this packaging unit = the approval process is not yet completed

= Layer Individual possible – see page 7

Safety gear

According to German DGUV 38 regulations, equipment to prevent falls by personnel must be provided for work areas and walkways where the height of the fall is more than 2.00 m.

The **PPE safety harness AX 60 C** has impressive features:

- ▶ Comfortable, padded and ergonomic back support
- ▶ Convenient tool holders and click-locks for easy fastening
- ▶ High operational dependability and absolute freedom from maintenance, plus very simple fastening
- ▶ Operating errors are not possible, as the equipment operates in any position
- ▶ Excellent running even under gruelling working conditions
- ▶ Enormous distribution of forces in the event of a fall.

Before use, visual checks must be performed regularly to ensure correct working order. In accordance with German BGR 198 regulations, all personal safety equipment must be inspected at least once a year by an expert. The maximum permissible period of use for the equipment must not be exceeded.

1



3



2



Railing clamp

Railing clamp

According to German regulations DGUV 38 relating to construction work, a fall protection system must be provided for work areas and walkways on roofs and intermediate levels where the height of the fall is more than 2.00 m. The Layher railing clamp meets these requirements for securing of concrete floors and fascias of 16 – 33 cm height and of flat roofs.

The back guard must be made in accordance with applicable regulations from tube / coupler, modular or frame scaffolding. The bay widths can be freely selected, max. 3.07 m long.

4

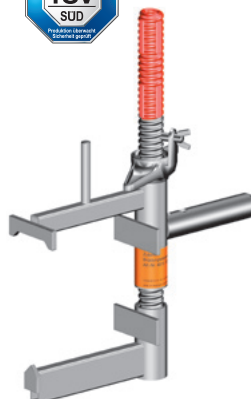

When attached to floors, toe boards must be provided, and the vertical stile must be attached over the spindle.

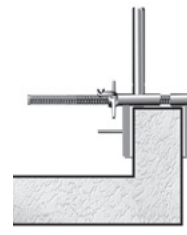

When attached to fascias, no toe boards are required, and the vertical stile must be attached over the spigot.

Pos.	Description	Dimensions L/H x W [m]	Weight approx. [kg]	PU [pcs.]	Ref. No.
1	PPE safety harness AX 60 C with extension 0.50 m conforms to EN 361		1.8		5969.160 🕒
2	PPE flex safety rope, 2.00 m with fall arrester and snap hook FS 90, as per EN 354 / EN 355 self-shortening to reduce tripping hazards	2.00 m	1.1		5969.501 🇩🇪
3	PPE scaffolding construction set Pos. 1 and 2 Backpack, safety harness and safety rope 2.00 m (use exclusively for scaffolding construction)		3.5		5969.170 🇩🇪

Pos.	Description	Dimensions L/H x W [m]	Weight approx. [kg]	PU [pcs.]	Ref. No.
4	Railing clamp	0.58	7.0	40	4015.100 🇩🇪

Example for use of the railing clamp on fascia:



Example for use of the railing clamp on floor slab:

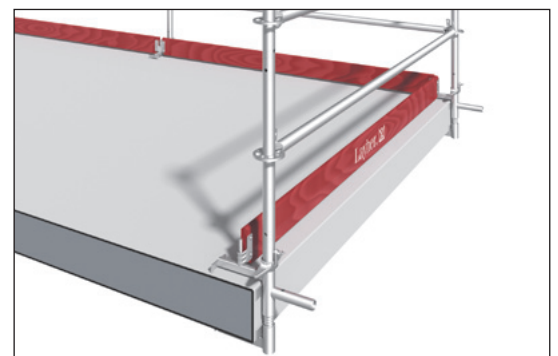

WS = wrench size PU = packaging unit 🇩🇪 = available ex works 🕒 = delivery time on request 🇩🇪 = only available in this packaging unit 🚧 = the approval process is not yet completed

IND = Layher Individual possible – see page 7

Parts for mobile scaffolds

Castors

The mobile solution for birdcage, bridge or suspended scaffolding is often the best alternative in terms of technical suitability, scheduling and price. In this field too, the choice, the delivery capability and not least the experience of the manufacturer point to Layher. If scaffolding is made mobile using castors, DIN 4420-3 applies. For these rolling towers, verification of structural strength is required.

Robust castors with twin brake (it brakes wheel and slewing ring) for various loads, offer a safer mobility of the scaffolding – without high effort.

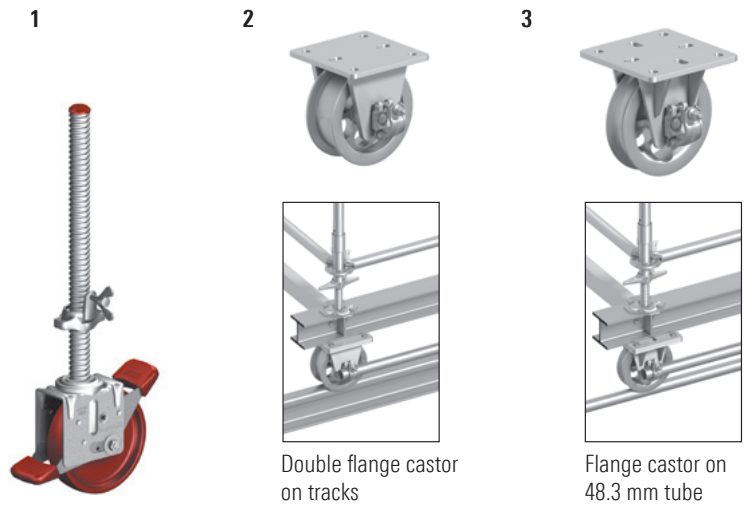

Scaffolding pallets

Tube pallets

in square shape (85) 5 or in rectangular shape (125) 4. The pallets are open on all sides. Tubes, standards, guardrails, diagonal braces, toe boards are transported and stored with this pallet. The empty pallets, stored permanently in the base frame using pallet posts, can be transported and stored in a space-saving way.

Tube pallet 125 4

Following can be transported: 80 standards or 99 toe boards or 155 ledgers (pay attention to the perm. load of 1,500 kg) or 28 steel decks 0.32 m.

Modular pallet and skeleton box 6/7

The palette or the skeleton box can be stacked with Euro pallets. Crane eyelets at top; an opening allows stacked material to be removed even if several pallets are stacked one above the other. The integrated timber base plate is 30 mm thick and it's nailed onto 50 x 50 mm square timbers.

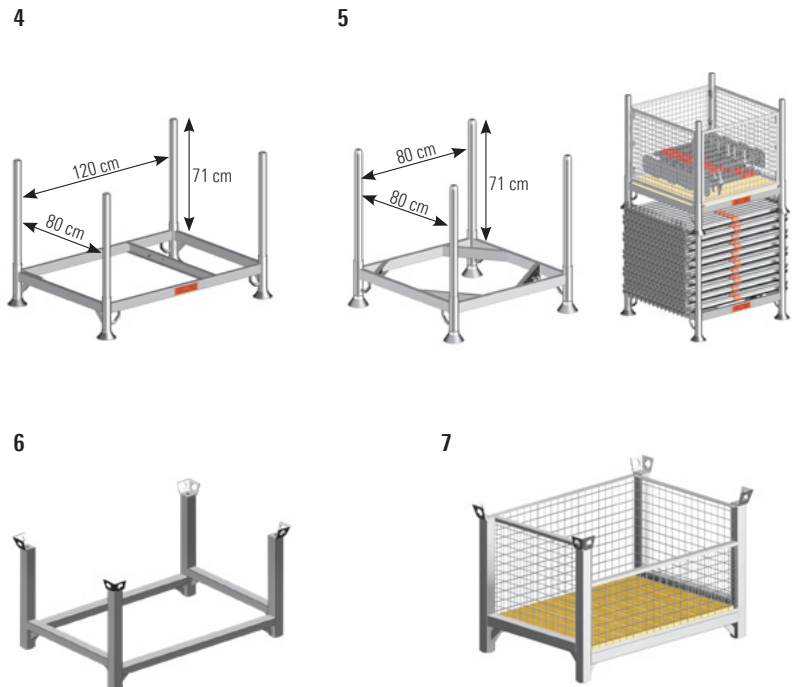

More pallets you'll find in the catalogue System-free Accessories.



Tools



The three-piece **scaffolding identification pad 10** with carbon copy developed to tag work scaffolding. The right part is the inspection record for your files. Your client gets the carbon. On the back side of the carbon, important application notes are listed.



The **high-quality scabbling pick 11** on the hammer head ensures a consistently safe use. The additional hardened inner tube provides a standard breaking strength. In addition, the reinforced scabbling pick has a patented head-stem-connection, which also forgives failures. The orange handle provides good handling, good cushioning and low-fatigue working.

Identification and prohibition signs for work scaffolding as per DIN EN 12811-1. Suitable **see-through pocket 12** made of transparent plastic for weather protection.



Pos.	Description	Dimensions L/H x W [m]	Weight approx. [kg]	PU [pcs.]	Ref. No.
1	Castor 1000 Plastic wheel, dia. 200 mm. With base plate, adjustment range 0.30 – 0.60 m, spindle nut with lock, with twin brake lever and load centering when braked. Wheel and slewing ring can be locked. Permissible load 10 kN (braked and unbraked)	dia. 0.20	6.3	70	1260.201
2	Double flange castor T17 , 75 mm Secured by top plate, hole pattern 170 x 170 mm, dia. 18 mm, external dia. 238 mm, internal dia. 200 mm, without brake. Permissible load 31 kN	dia. 0.238	21.4	40	5216.076 
3	Flange castor for 48.3 mm tube Secured by top plate, outer hole pattern 170 x 170 mm, dia. 18 mm, inner hole pattern 126 x 126 x 13 mm (slot hole 13 x 28 mm) without brake. Permissible load 31 kN	dia. 0.23	16.8	40	5221.048 

Pos.	Description	Dimensions L/H x W [m]	Weight approx. [kg]	PU [pcs.]	Ref. No.
4	Tube pallet 125 Steel, hot-dip galvanized, length of pallet posts: 0.86 m, load 1,500 kg, dimensions 1.37 x 0.97 m	1.37 x 0.97	32.0	10	5105.125
5	Tube pallet 85 Steel, hot-dip galvanized, length of pallet posts: 0.86 m, load 1,500 kg, dimensions 0.97 x 0.97 m	0.97 x 0.97	30.8	10	5105.085
	Timber base plate	0.88 x 0.88	4.1	50	5104.088 
	Mesh box insert Steel, hot-dip galvanized, load 1,500 kg		22.0	10	5104.086 
	Plug tubes 860 for tube pallet 125 and 85	0.86	2.6	4	6494.751 
6	Modular pallet Steel, hot-dip galvanized, internal dimensions 1.08 x 0.68 x 0.61 m load 2,000 kg, perm. onload 6,000 kg stackable with Euro pallets	1.20 x 0.80	45.0	5	7042.004
7	Modular skeleton box with timber base plate Steel, hot-dip galvanized, internal dimensions 1.08 x 0.68 x 0.61 m load 2,000 kg, perm. onload 6,000 kg stackable with Euro pallets	1.20 x 0.80	85.8		5113.002

Pos.	Description	Dimensions L/H x W [m]	Weight approx. [kg]	PU [pcs.]	Ref. No.	
8	Ratchet spanner with reinforced head	WS 19	0.32	0.7	25	4740.019
		WS 22	0.32	0.7	25	4740.022
9	Magnetic spirit level		0.4		4006.666	
10	Scaffolding identification pad Pad with 50 + 50 pieces (Original + Carbon) with centre perforation and foldover as carbon-block	DIN A4	0.5		6344.500 	
11	Scabbling pick 600 g reinforced	0.32	0.8		4421.051 	
12	See-through pocket T17 with STOP for Ref. No. 6344.500 with lock flag when inspection record is not inserted	0.30 x 0.17	0.4	10 	6344.011	

WS = wrench size PU = packaging unit  = available ex works  = delivery time on request  = only available in this packaging unit  = the approval process is not yet completed

 = Layher Individual possible – see page 7

Index

A		
Access deck	24, 26	
Access ladder	24	
7 rungs	25	
Accessories	32	
Adapter for heavy-duty column	51	
Adapter plate	63	
Adjustable foot	61	
Adjustment plate	10	
Adjustment plate for base plate	11	
Advance guardrail post	64, 65	
Advance guardrail system (AGS)	64	
Allround bridging system	50	
Allround FW chord	48	
Allround FW diagonal rod	48	
Allround FW post	48	
Allround Guardrail System	14	
Guardrails	14	
Standard	14	
Allround O-ledger LW	16, 17	
Allround rosette cover	33	
Allround wall tie	33	
0.80 m	32	
Aluminium section beam with wood	59	
Alu U-beam	53	
Anchoring	32	
Anchor plate	52	
Anchor plate tube	53	
ARGS double end guardrail	15	
ARGS eaves bracket	14, 15	
ARGS guardrail	15	
ARGS guardrail adapter	15	
ARGS guardrail support	15	
ARGS initial standard LW	15	
ARGS standard LW	15	
Assembly aid for system handrail	45	
Assembly guardrail	65	
B		
Ballast	65	
Base collar	12, 13	
0.26 m, for modular stairway	47	
long	12	
Base piece		
for heavy-duty column	61	
Base plate	10, 61	
60	11	
60, solid	11	
80, reinforced	11	
for heavy-duty column	61	
Base plate support	54, 55	
Bay length adaptation	58	
Beam clamp	61	
Beam connector	59	
Beam connector bolt	59	
Beam spigot	53	
Bending strength	16	
Blind rivet	45	
Bolt	40, 49, 51, 53	
Bracket	34	
1.09 m wide	34	
Bracket brace	35	
2.05 m	34, 35	
Brick guard	36	
Bridging system	50	
C		
Castor	58, 68, 69	
Castor adapter	59	
Chord	51	
Clamping nut	51	
Comfort stairway	38, 39	
Compact stairtower	62	
Compensation element	61	
Construction stairtower 200	40	
Corner deck	24	
adjustable	25	
Countersunk bolt M8 x 30	45	
Coupler	32	
Cross-connector	54, 55	
Cross head jack		
45	11	
45, solid	10	
D		
Diagonal anchoring	51	
Diagonal brace	20	
steel	21	
Diagonal rod	51	
Double coupler	33	
Double flange castor	69	
Double support	60	
E		
End-AGS	64, 65	
End caps for system handrail tube	45	
End plate for transport box	65	
F		
Fastening for crane transport	59	
Flange castor	69	
Flat roof ballast	64, 65	
Flat roof guardrail post	64, 65	
Flat roof guardrail stiffener	64, 65	
Flat roof shift preventer	64, 65	
Flat roof side protection	64	
Flat roof toe board support	65	
Flat roof wheel set	65	
FlexBeam	52, 54	
FlexBeam crosspiece	54, 55	
FlexBeam end bracket adapter	53	
FlexBeam spigot	52	
Front beam adapter	52	
FW chord	49	
FW diagonal rod	49	
FW endfitting	49	
with turnbuckle	49	
FW guardrail adapter	49	
FW nut	49	
FW post	49	
extended	49	
single-side connection	49	
FW System	48	
G		
Gap cover	28, 63	
Gap deck	28	
Guardrail	19	
for modular stairway	47	
T12 with child protection	43	
Guardrail adapter	54, 55	
Guardrail fixing device	43	
Guardrail for modular stairway	46	
Guardrail for stairs		
500 T12, 5 steps	43	
500 T12, 9 steps	43	
750 T12, 2 steps	43	
750 T12, 5 steps	43	
750 T12, 8 steps	43	
Guardrail standard	40, 41	
H		
Half-coupler with plate	63	
Half-coupler with toe board pin	31	
Head jack	10, 61	
45	11	
60	11	
for heavy-duty column	61	
Head part, for heavy-duty column	61	
Head plate	61	
Heavy-duty column	60	
Heavy Duty Tower XL	60	
Hexagon head bolt M12 x 35	51	
Hinged pin	12, 13	
Hollow wall bracket	62	
Hollow wall bracket adapter	63	
Horizontal support element	16, 18	
I		
Individual stamping	26	
Individual toe board	30	
Initial stairway guardrail	39	
Initial standard LW		
steel	13	
Internal stairway guardrail	38	

Index

Stalu deck	22	T		U-ledge	18, 31
Standard adapter	52	Telescopic ARGs guardrail	14, 15	0.73 m	30, 35
female	53	Telescopic gap deck	28	aluminium	17
male	53	Telescopic U-gap deck	29	for lattice beam	46, 47
Standard connector	52, 53	telescoping assembly guardrail	64	reinforced, aluminium	19
Standard lock	12, 13, 65	Tie rod adapter	52, 53	reinforced LW T14, steel	19
Standard LW	12, 13, 15	Tilting pin adapter	65	steel deck - O-ledge	19
0.67 m	13	Timber beam support	53	steel deck - steel deck	19
1.17 m	13	Toe board	30	with bearer	63
aluminium	13	Toe board support	64	with gap cover	35
without spigot	13	Tools	68	with gap cover, 0.11 m width	43
steel	13	Tower	60	U-ledge deck configuration	18
without spigot	13	Tube pallet	68	U-ledge LW T14	
with pressed-in spigot	13	85	69	steel	17
with integrated spigot	12	125	56, 69	U-ledge reinforced LW T14	
without spigot	12, 13	Tube pallet 125	68	steel	19
STAR double end guardrail	57	Turnbuckle	48	U-lift-off preventer	18, 46
STAR frame	56	Twin wedge coupler	32, 33, 61	T8	19
STAR guardrail	57	U		T9	19
STAR guardrail adapter	57	U-access deck	25	Universal U-lift-off preventer	19
STAR guardrail support	57	steel, 0.64 m wide	25	U-/O-stairway stringer 200	40, 41
STAR internal guardrail fixing device	57	U-alu deck, perforated, 0.32 m wide	23	U-robust access deck	
STAR lift-off preventer	57	U-aluminium access deck		0.61 m wide	
STAR O-ledge with half-coupler	57	0.61 m wide	25	with integrated access ladder	25
STAR pallet	57	with integrated access ladder	25	0.61 m wide, hatch offset	25
STAR roof guard support	57	U-board bearer	31	with integrated access ladder	25
Starting stairway	39	U-bracket, with 2 hooks	34	U-robust deck	
STAR transport safeguard	57	U-bridging ledger		0.61 m wide	23
Steel deck		aluminium	19	U-side part	41
LW	22	U-console bracket		U-stair	63
T4	22	0.28 m wide	35	U-stair head section	
Steel gap sheet	28	0.39 m wide	35	0.60 m	41
0.32 m	29	0.45 m wide, with 2 wedge-heads	35	0.95 m	41
Steel plank	28	0.73 m wide	35	U-stairway stringer 200	41
0.20 m	29	0.73 m wide, with 2 wedge-heads	35	U-stairway stringer 500	
0.30 m	29	1.09 m wide	35	5 steps	43
Step cover	44, 45	with 2 hooks	35	9 steps	43
Stringer		0.36 m wide	35	U-stairway stringer 750	
for modular stairway	46, 47	0.73 m wide	35	2 steps	43
Support beam	51	U-console corner deck	25	5 steps	43
Support element	51	U-corner deck	25, 27	8 steps	43
Support for double standard	51	adjustable, with toe board	24	U-stalu deck T9	
Support for flat roof guardrail	64, 65	for circular scaffolding 30°	25	0.19 m wide	23
Suspension shoe	52, 53	U-deck	31	0.32 m wide	23
Swing door	40	U-gap cover		0.61 m wide	23
0.73 m	41	with claws	43	U-STAR frame	57
1.00 m	41	U-gap deck	29	LW	57
Swivel coupler	33	U-interchangeable ledger	19	U-steel deck	25
Swivelling base plate		U-interchangeable ledger LW reinforced	19	U-steel deck, 0.19 m wide	23
60, reinforced	10, 11	U-lattice beam		U-steel deck T4, 0.32 m wide	23
Swivelling head jack	45	aluminium	46, 47	U-steel toe board	31
Swivelling top spindle	10	LW, steel	47	U-suspension	22, 24
System handrail	44	steel	46	U-toe board	
System handrail holder	45			aluminium	31
System handrail tube	45			wood	31
				U-walkway beam	36, 37
				U-Xtra-N deck	22
				0.61 m wide	23
				U-Xtra-N hatch-type access deck	
				0.61 m wide	
				with integrated access ladder	25

V

Vertical support elements 12

W

Wall Bracket 54

Wall connection unit 54, 55

Wall tie 33

Wedge-head coupler 32, 51

rigid 33

swivelling 33

Wedge-head design with AutoLock function 16

Wedge spindle swivel coupler 10, 11

Weight saving 16

Wheel set 64



Layher is your dependable partner with more than 75 years of experience. "Made by Layher" always means "Made in Germany" too – and that goes for the entire product range. Superb quality – and all from one source.

Proximity to the customer is a central factor behind Layher's success – geographically speaking too. Wherever our customers need us, we will be there – with our advice, assistance and solutions.

-  **SpeedyScaf**
-  **Allround Scaffolding**
-  **System-free Accessories**
-  **Protective Systems**
-  **Shoring**
-  **Event Systems**
-  **Rolling Towers**
-  **Ladders**
-  **Software**



Headquarters in Eibensbach



Plant 2 in Gueglingen

Layher 

More Possibilities. The Scaffolding System.

Wilhelm Layher GmbH & Co KG
Scaffolding Grandstands Ladders

Ochsenbacher Strasse 56
74363 Gueglingen-Eibensbach
Germany

Post Box 40
74361 Gueglingen-Eibensbach
Germany

Telephone +49 (0) 71 35 70-0
Telefax +49 (0) 71 35 70-2 65
E-mail export@layher.com
www.layher.com

